

batterX[®]







i-Series Manual



SAFETY INSTRUCTIONS

The contents of this manual are subject to change without notice. The latest version of the manual is available at www.batterx.de or can be requested by emailing info@batterx.de.

SYMBOL LEGEND

	Refers to the installation instructions
	Risk of danger
	Risk of electric shock
	Risk of electric shock. Discharge time of internal residual charge: 10 minutes
	Hot surface
	Relates to recycling

GENERAL SAFETY



Before installing and/or starting up and using the system, read all the instructions and safety information in this manual. This manual is intended for qualified personnel. The tasks described here should only be performed by qualified personnel. Keep this manual for future reference. Use the device only as described in this manual.



Do not disassemble any parts unless explicitly instructed to do so. The manufacturer's warranty is void if the device is modified or disassembled without authorization.



Do not use any components if they show visible damage. In this case, inform your supplier or batterX.



Installers must have professional training and attend a training course provided by batterX.



The use of this inverter for power generation and feeding into the power grid usually requires approval from the local energy supply authority. Please check this before connecting.



The temperature of some parts of the inverter may exceed 60 °C during operation. To avoid burns, do not touch the inverter during operation. Allow it to cool down before touching it.



All procedures, such as transport, storage, setup and commissioning, operation, and maintenance, must comply with the applicable laws, regulations, standards, and normative requirements of the individual installation site. These must be checked by the customer in good time before installation.



Please observe the requirements for the installation site. Among other things, ensure adequate ventilation.





The products must not be used to supply power to medical devices or life-support systems.



The products must not be used in facilities with radiation control, nuclear reactors, and facilities related to nuclear safety or the use of nuclear energy, as well as in facilities that may come into direct contact with patients.



The products must not be used or installed in locations where vibrations may occur. For example, aircraft, ships (boats, yachts), cars, or trains are not permitted.



The products must not be used or installed near fuel or flammable materials.



The products are intended for stationary storage applications.



At the end of their service life, the various components must be disposed of properly by a certified specialist company.

ELECTRICAL SAFETY



The system has fixed specifications for the power supply and must only be used with these voltages/values. Do not use any other power source. Do not make any changes to the power supply or electrical connections. Only connect the device to power sources that are properly fused/protected.



When wiring the lithium battery terminals, please switch off the circuit breaker or switch of the lithium battery to avoid injury from high voltage.



All electrical installations must comply with local electrical safety regulations. Please ensure, among other things, that the correct fuse protection or circuit breakers are selected!



A stable and reliable grounding system must be provided for safety and normal operation. All battery modules must be grounded, with a resistance of less than 1 Ω .



The batteries of batteries of batterX i-Series cannot be combined with other battery types, models, or manufacturers.



To avoid the risk of electric shock, the service technician should disconnect all AC and DC power sources from the system and check for any dangerous voltages before starting any work on the system. Simply switching off the device does not reduce the risk! The internal capacitors may remain charged for up to 10 minutes after the power sources have been switched off.

FIRE AND SHORT-CIRCUIT PROTECTION



Ensure correct polarity when connected to the power supply. Make sure that all cables are correctly dimensioned and mechanically relieved. Do not operate the system in a damp environment or near flammable materials.



The following activities with the batteries are strictly prohibited: Do not throw into fire, do not combine with other battery types, do not charge beyond the specified value, do not connect improperly, and do not short-circuit, as this may cause overheating, explosion, or leakage of the cell contents. Parallel connection of batteries is prohibited.



A carbon dioxide, Novac1230, or FM-200 fire extinguisher must be available near the equipment. Extinguish the fire before the battery catches fire. If the battery catches fire, people must be evacuated immediately and without hesitation.

BATTERIES

The materials contained in the batteries only pose a hazard if the integrity of the cell or battery is compromised and/or if the battery is physically, thermally, or electrically abused. Hazards to be expected under these conditions:

- Skin irritation
- Severe eye irritation
- Allergic skin reaction
- Damage to organs (bones, teeth) with prolonged or repeated exposure
- Toxic to aquatic organisms
- Harmful to aquatic organisms with long life cycles

Lithium iron phosphate (LiFEPO₄) battery or cell:

	Hazard warning label
	Health hazard
	It is very toxic to aquatic organisms



IN CASE OF A LEAKING BATTERY

Due to the corrosive nature of the electrolyte, protective gloves/protective clothing/eye protection/face protection must be worn to avoid direct contact. If contact with the leaking substance occurs, the following measures must be taken:

People must be evacuated immediately and given medical attention.

- If inhaled: Contaminated work clothing must not leave the workplace. It must be washed thoroughly before reuse.
- If on skin: Wash with plenty of water and seek medical advice immediately.
- If in eyes: Rinse cautiously with water for several minutes. Remove contact lenses, if present and easy to do. Continue rinsing and seek medical advice/attention.
- If swallowed: Induce vomiting and seek medical attention immediately.

DECLARATION

batterX GmbH reserves the right not to provide any warranty in the following cases:

- Damage caused by improper transport.
- Damage caused by improper storage, installation, or use.
- Damage resulting from the installation and use of devices by laypersons or untrained personnel.
- Damage caused by failure to follow the instructions and safety precautions in this document.
- Damage resulting from operation in an environment that does not meet the requirements specified in this document.
- Damage resulting from operation outside the parameters specified in the applicable technical specifications.
- Damage resulting from unauthorized disassembly, modification of products, or alteration of software codes.
- Damage caused by abnormal natural conditions (force majeure, such as lightning, earthquake, fire, storm, etc.).
- Damage caused by installation or operation that does not comply with local standards and regulations.
- After the warranty period for the products has expired.

TABLE OF CONTENTS

1. Scope of delivery	7
2. Installation instructions.....	11
I. Installation location.....	11
II. Equipment.....	11
3. Overview.....	12
I. Hybrid inverters.....	18
II. Batteries.....	20
a. S1 BASE.....	20
b. S1 BAT 2.5.....	20
c. S1 BMS.....	21
d. S1 MULTI.....	22
III. EMX.....	23
IV. E-meter.....	25
4. Installation.....	26
I. Hybrid inverter.....	26
II. Batteries.....	30
a. S1 BASE.....	30
b. S1 BAT 2.5.....	31
c. S1 BMS.....	32
d. S1 MULTI.....	35
III. EMX.....	37
IV. E-meter.....	38
5. Wiring.....	39
I. Hybrid inverter.....	39
II. Batteries.....	52
a. S1 BASE.....	52
b. S1 BAT 2.5.....	52
c. S1 BMS.....	52
d. S1 MULTI.....	54
III. EMX.....	57
IV. E-meter.....	59
6. Commissioning.....	61
7. Installation routine.....	63
8. Dynamic electricity prices.....	76



- I. Setup 76
- II. Display in the portal 87
- 9. Time-controlled battery charging 89
- 10. Signal-controlled battery charging 91
- 11. Warranty processing 93
- 12. Maintenance 97
- 13. emergency stop funtion 99
- 14. Use of optimizers 100
- 15. Battery expansion 100
- 16. API und Modbus TCP/IP 100
- 17. Controllable consumption devices 101
- 18. black start 103
- 19. Error codes 105



1. SCOPE OF DELIVERY

The components are thoroughly tested and strictly inspected before delivery. However, damage may occur during transport. Therefore, please carry out a thorough inspection upon receipt of the delivery. If there is any damage or missing parts, please contact your supplier or batterX and include photos to facilitate the process.

INVERTER i10/i20

The following accessories are included in the scope of delivery of the i10/i20 inverter. Please check that all accessories are included in the packaging upon receipt of the goods.

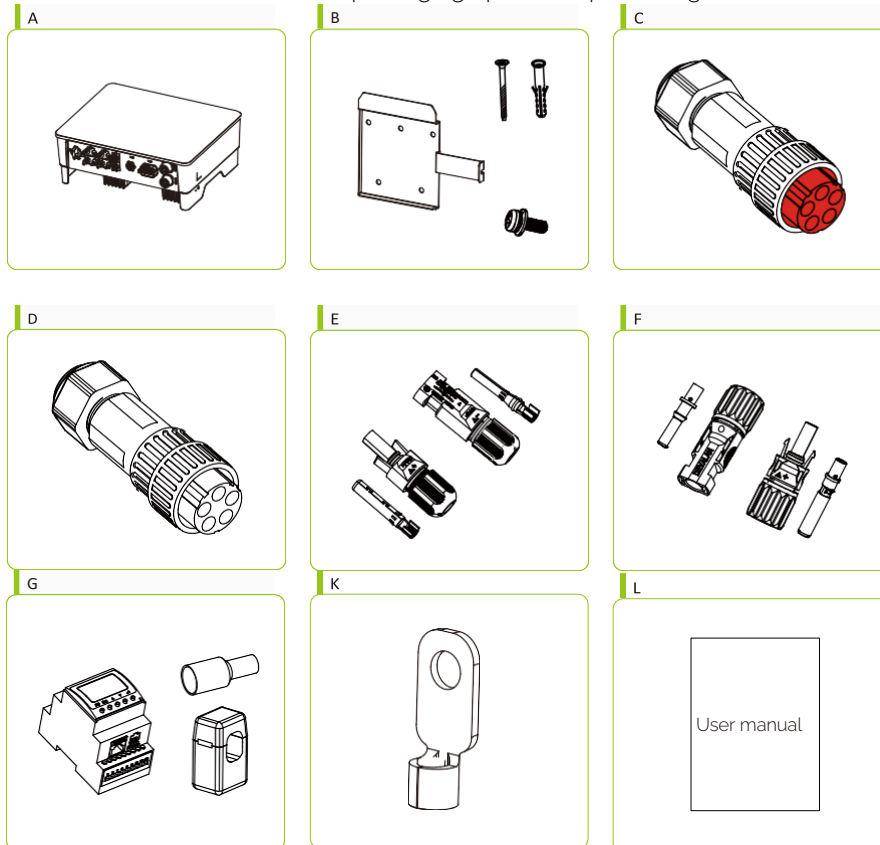

No	Name and quantity	Comment
A	Inverter (1 pc.)	
B	Wall bracket (1 pc.), wall plug set (5 pcs.), M5 screws (1 pc.)	
C	AC plug for mains connection (1 pc.)	Red
D	AC plug for backup output connection (1 pc.)	Black, U-profile pin
E	PV terminal (i10/i20 4 pairs)	Black, O-profile pin
F	Battery plug: 1 replacement pair.	Plug blue, replacement plug
G	Electricity meter with 3 current transformers (1 pc.)	
K	Grounding terminal (1 pc.)	
L	User manual	

i30 INVERTER

The following accessories are included with the i30 inverter. Please check that all accessories are included in the packaging upon receipt of the goods.

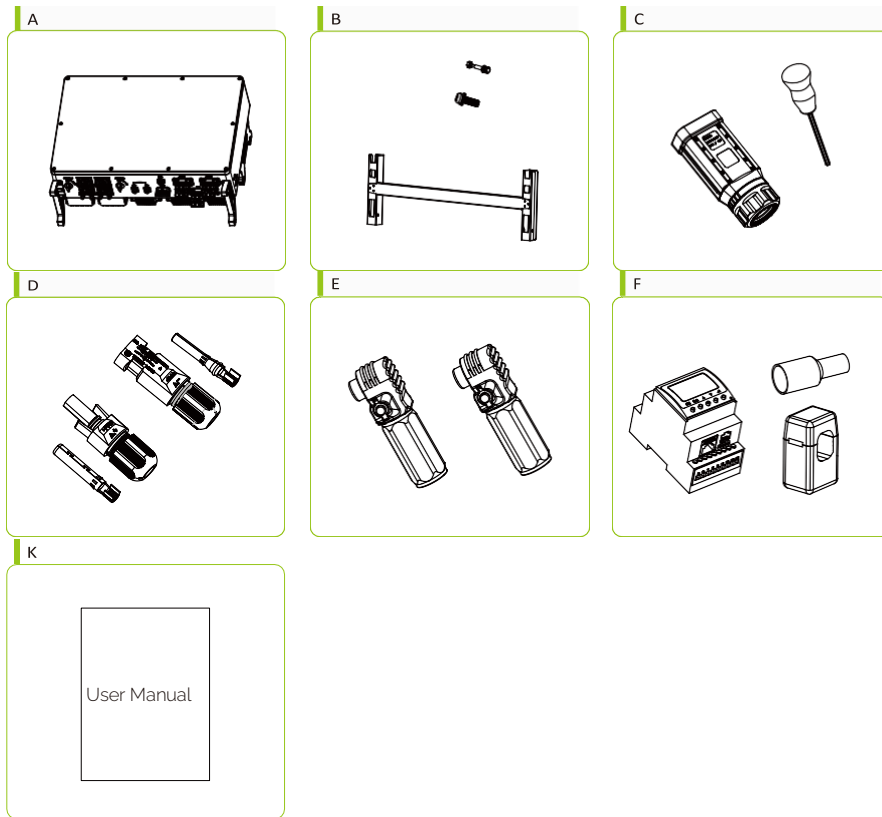

No	Name and quantity	Comment
A	Inverter (1 pc.)	
B	Inverter bracket (1 pc.), screw assembly (4 pcs.), M6 screws (2 pcs.)	
C	AC connector set (3 pcs.)	
D	PV plug connector (i30 8 pairs)	
E	Battery plug: 1 pair already connected to cable. Plus 1 spare pair	For connecting i30 to BMS when installing a battery tower.
F	Electricity meter with 3 current transformers (1 pc.)	
K	User manual	

BATTERY TOWER

The battery tower comes with the following accessories. Please check that all accessories are included in the packaging upon receipt.

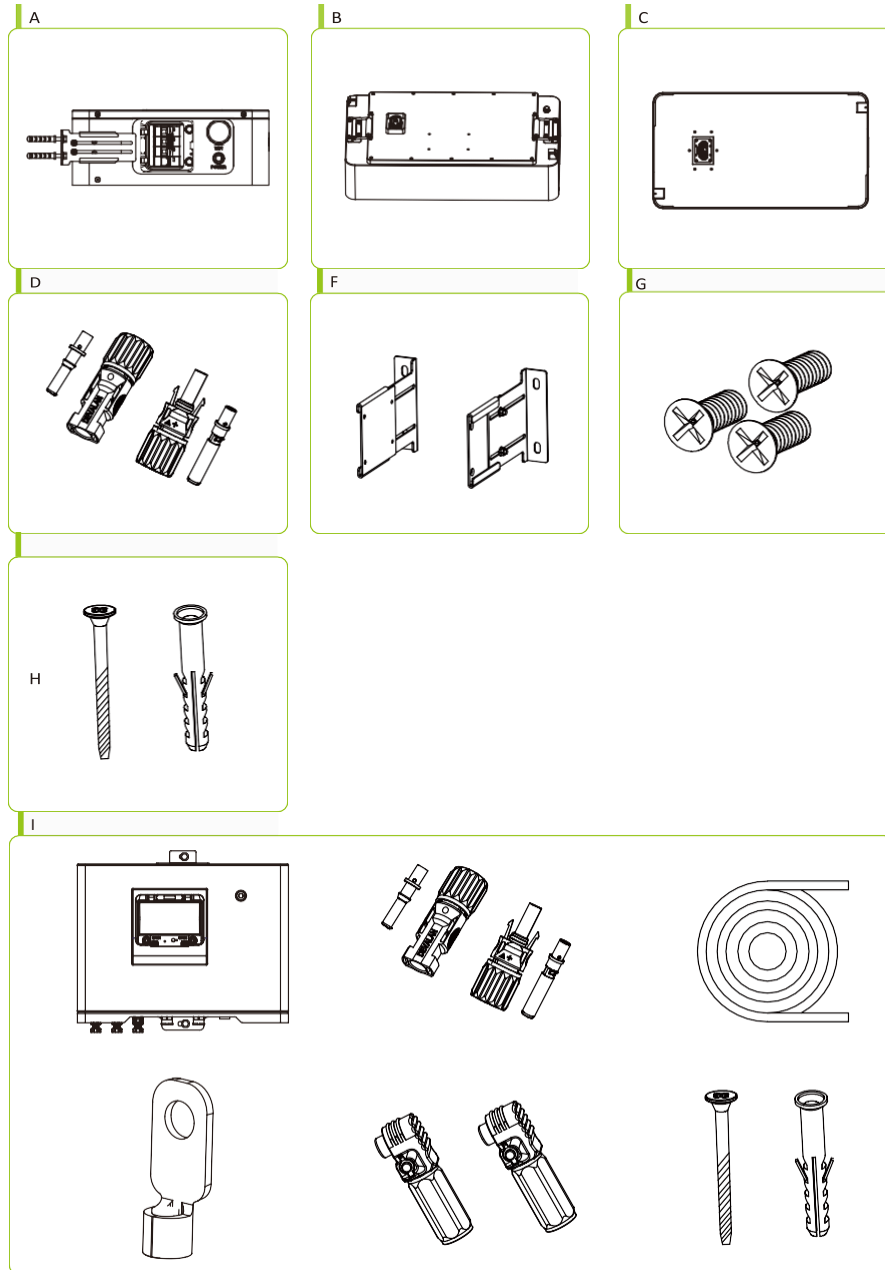

No	Name and quantity	Quantity	Comments
A	Control module (S1 BMS), 1 pc.	1	With PE terminal and screw.
B	Battery module (S1 BAT 2.5), 2-10 pcs.	2-10	Based on one battery tower
C	Base module (S1 BASE), 1 pc.	1	
D	Battery plug, 1 pair already connected to cable. Plus 1 spare pair.	1 pair	For connection between BMS and i10/i20 or BMS and MULTI
E	Waterproof cable entry for RJ45 plug, 3 pcs.	3	Not used
F	Module wall brackets, 2 pcs.	2	For BMS module
G	M4*8 countersunk screw, 6 pcs.	6	Fastening the wall brackets to the BMS module
	M4*12 countersunk screw, 2 pcs.	2	Connecting the BMS module to the battery module (stack)



	M4*12 countersunk screw, 2 pcs.	2	For battery stack. Based on one battery module
H	M6*60 expansion screw, 4 pcs.	4	For wall mounting the BMS module on the wall
I	MULTI with accessories When using multiple battery towers (> 25 kWh)	1	Multi x1 <ul style="list-style-type: none"> - Pre-assembled cable for connecting MULTI and i10/i20 1x - Pre-assembled cable for connecting MULTI and i30 1x - PE cable lug x 2 - M6x60 screw + wall plug x 2 - Battery plug x 3 spare pairs - BMS communication cable 2m x 3. - Replacement 150A battery plug x 1, replacement pair (orange and black).

EMX

The following accessories are included with the EMX. Please check that all accessories are included in the packaging upon receipt of the goods.

- EMX incl. communication cable for connection to inverter
- BMS cable
- E-meter cable
- Mounting hardware



Attention! The required plug-in power supply is not included in the scope of delivery. Use a plug-in power supply with the following technical parameters:

- 230 VAC / 12 VDC
- 2.5 A,
- Protection class II
- At least 30 W power
- Max. cable length of 3 m

2. INSTALLATION INSTRUCTIONS

I. INSTALLATION LOCATION

Ensure that the installation location meets the following conditions:

- The system must not be installed in potentially explosive areas.
- Mount on a stable, non-combustible surface.
- The installation height must be considered.
- It should preferably be installed in a technical or electrical room.
- Install in a dry, clean environment.
- Avoid direct sunlight, excessive dust, or vibrations.
- The ambient temperature should be between 5°C and 40°C, and the relative humidity between 5% and 95%.
- Constant temperature and humidity.
- The system must not be exposed to corrosive gases.
- There must be no liquid, flammable, or explosive materials in the installation area.
- The installation should not block access to other devices.
- The system is designed for indoor use.
- The area must be protected from moisture.
- Suitable ventilation must be provided.
- Keep out of reach of children and pets.
- The maximum installation altitude must not exceed 2000 m above sea level.
- Please refer to the data sheets for the individual components.

II. EQUIPMENT

During installation, ensure that safety equipment (such as safety shoes, safety goggles, and work gloves) and insulated tools are used correctly.



Insulated gloves



Safety goggles



Safety shoes

Do not wear metal objects such as rings, watches, and key chains, and take appropriate safety precautions.

Do not store uninsulated tools in pockets or tool belts while working near the battery to avoid short circuits and injury.

3. OVERVIEW

The system consists of various components, which are described in more detail below:

- i10/i20/i30 hybrid inverter
- S1 BAT stackable high-voltage batteries
- S1 MULTI, when using multiple battery towers
- EMX, monitoring & control

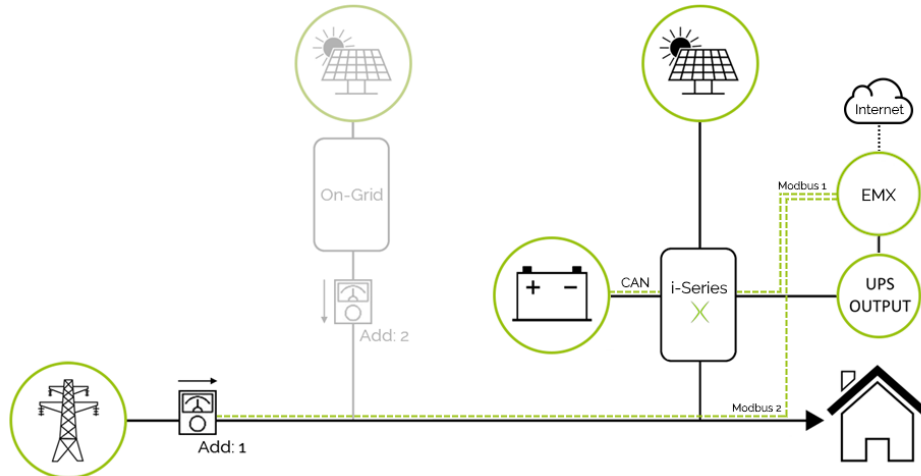

It is recommended to install a maintenance switch between the inverter and the protected loads.

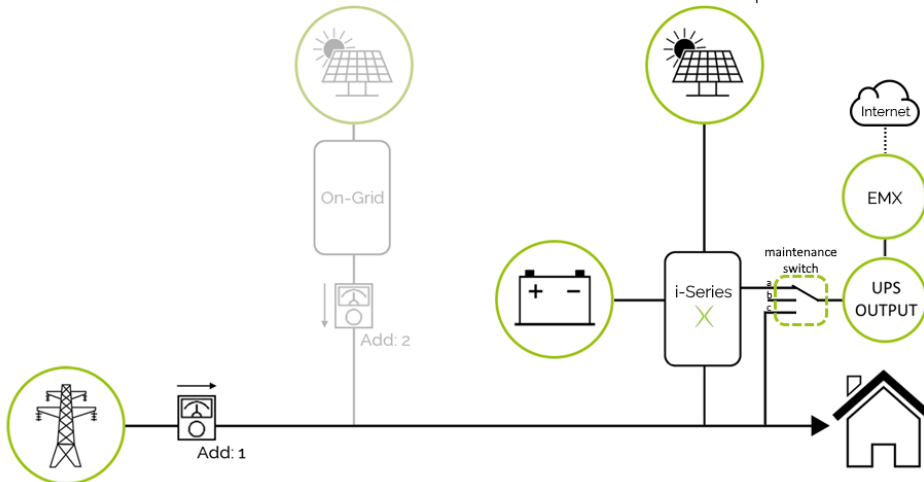

The system is not suitable for supplying life-supporting medical devices. It cannot guarantee a backup power supply under all circumstances.

The power grid types suitable for the i-Series are TN-S, TN-C, TN-C-S, and TT. When used in a TT power grid, the voltage between N and PE is less than 30 V.

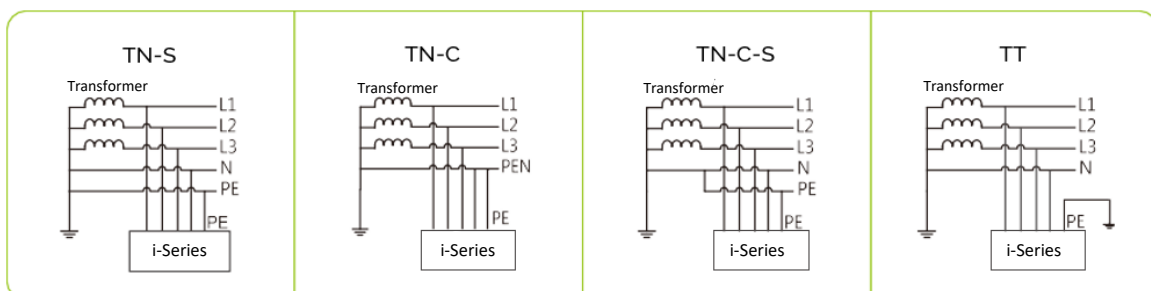

Definitions

Emergency power

If power is supplied via a separate connection in the event of a power failure, this is referred to as an emergency power system. If the output can be used without interruption, it is an emergency power system with UPS. The emergency power system should take over the supply within <20 milliseconds.

Emergency power is required wherever an uninterrupted power supply is essential and where even brief power fluctuations can cause considerable financial damage or endanger human health.

Backup power

In contrast, backup power is used to supply devices in an emergency but is not required on a time-critical basis. Here, the power supply may be interrupted for several seconds to minutes. The technical effort required to provide backup power is lower than for emergency power.

Discharge capacities of the system

When designing the system, it is important to understand what discharge capacities/power can be provided – during normal operation and in the event of a power failure. It should be noted that both the different inverters (i10; i20; i30) and the different storage sizes (S1 BAT 7.5 / 10 / 12.5 ...) can provide maximum power. The lower power rating is the decisive factor here. As a rule, you can remember the following:

i10	max. 10 kW, or 3.3 kW per phase
i20	max. 20 kW, or 6.6 kW per phase
i30	max. 30 kW, or 10.0 kW per phase

The batteries have a max. C-rate (= discharge rate; ratio of power to capacity of 1)

S1 BAT 7.5	max. 7.5 kW
S1 BAT 10	max. 10 kW
S1 BAT 12.5	max. 12.5 kW
S1 BAT 15	max. 15 kW
S1 BAT 17.5	max. 17.5 kW
S1 BAT 20.0	max. 20 kW
...	...

Due to the many different combinations of inverters and storage sizes, please refer to the data sheets for the system sizes. There you will find a detailed list of all power ratings.

General

Many backup power systems become overloaded during power outages because there is no power limitation. In emergency power situations, where protected consumers are clearly selected in advance, overloading is rather rare. It is therefore worthwhile to consider in advance which system makes sense for the customer.

In both cases, it is necessary to check what power is available in the event of a power failure and whether the PV system can continue to operate as an "island network" at the same time. This means that the battery can be recharged from the PV system during the day, even in the event of a power failure.

The physical connection to the inverter is labeled "Backup Output.". In this manual, it is referred to as the "UPS output", "emergency power output" or "emergency power output terminal." Depending on the design and connection of the system, there are different installation options with different functions, advantages, and disadvantages.

Installation option 1: "Normal" storage unit without use of the emergency power output

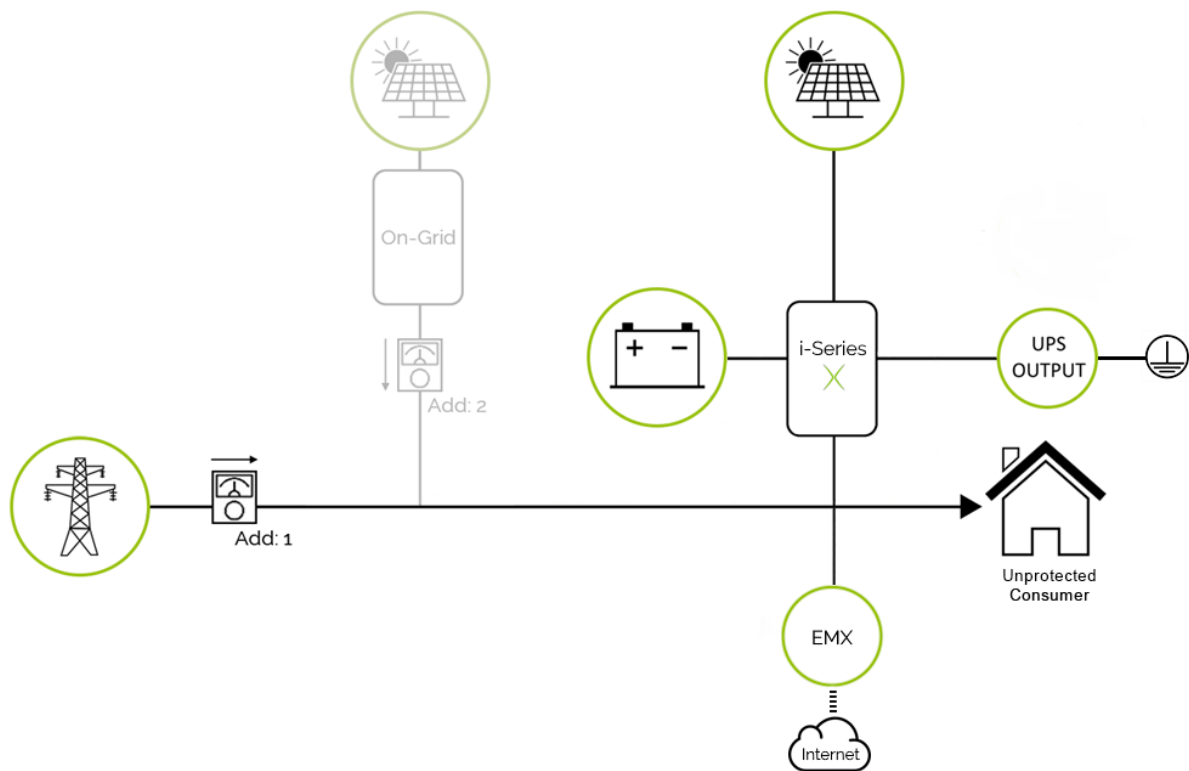

! *Caution: Connect the UPS output to earth, otherwise the installation routine will not run. See section "Commissioning."*

Description

The EMX (or its power supply) is connected in the unprotected area of the system. The UPS output is not used in this variant.

Advantage	Disadvantage
Simple installation	No use of the emergency power output; monitoring is no longer available in the event of a power failure.
	All consumers are unprotected and cannot be used in the event of a power failure.

Installation option 2: Emergency power system, socket in protected area (protected by circuit breaker and RCD)

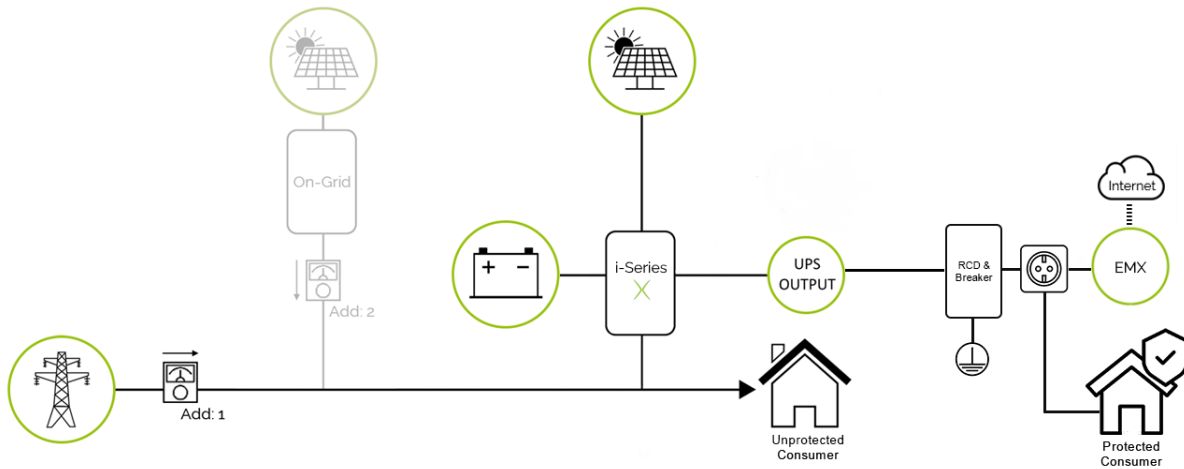

! *Caution: Connect the UPS output to earth, otherwise the installation routine will not run. See section "Commissioning."*

Description

The emergency power output is used in this variant. To ensure a safe supply to the protected consumers, appropriate safety devices (e.g., RCD and circuit breakers) must be installed between the UPS output of the inverter and the consumers. In this variant, the safety devices are installed in a suitable enclosure near the inverter. Please observe the relevant local laws and regulations. The EMX is supplied with power via a protected socket, as are selected for protected consumers.

! *Please ensure that you select suitable protected loads so that the emergency power output cannot be overloaded.*

! *Caution: The router must also be supplied via UPS output, otherwise there will be no internet connection and therefore no monitoring available in the event of a power failure!*

Advantage	Disadvantage
Monitoring and selected/protected loads are also available in the event of a power failure.	Additional RCD and circuit breaker in installation housing next to protected socket.

Installation option 3: Emergency power system with feed-back into the distribution board supplying selected loads

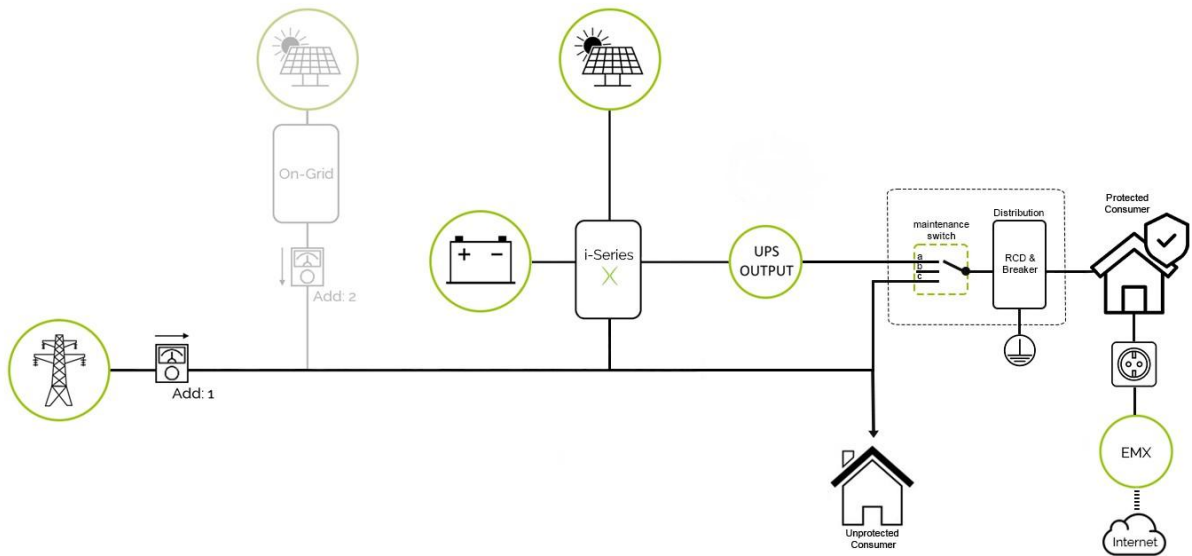

- Caution:** Connect the UPS output to earth, otherwise the installation routine will not run. See section "Commissioning."
- Make sure you select suitable protected loads so that the emergency power output cannot be overloaded.**
- Caution:** The router must also be supplied via UPS output, otherwise there will be no internet connection and therefore no monitoring available in the event of a power failure!

Description

Similar to installation option 2, but the UPS output cable is fed back into the meter cabinet/sub-distribution board. There, the protected area is again protected with an RCD and circuit breaker. By default, the manual maintenance switch is set to position a, which means that the selected loads are supplied by the UPS output of the inverter. In the event of a fault in the inverter, the manual maintenance switch can be set to position c, which means that the selected loads are supplied from the mains/grid.

Advantage.	Disadvantage
Monitoring and selected/protected consumers are also available in the event of a power failure.	Additional RCD and circuit breaker in meter cabinet/sub-distribution board.
No additional housing is required for backup fuse.	



Installation option 4: Emergency power system with feed-back into the distribution board and manual maintenance switch

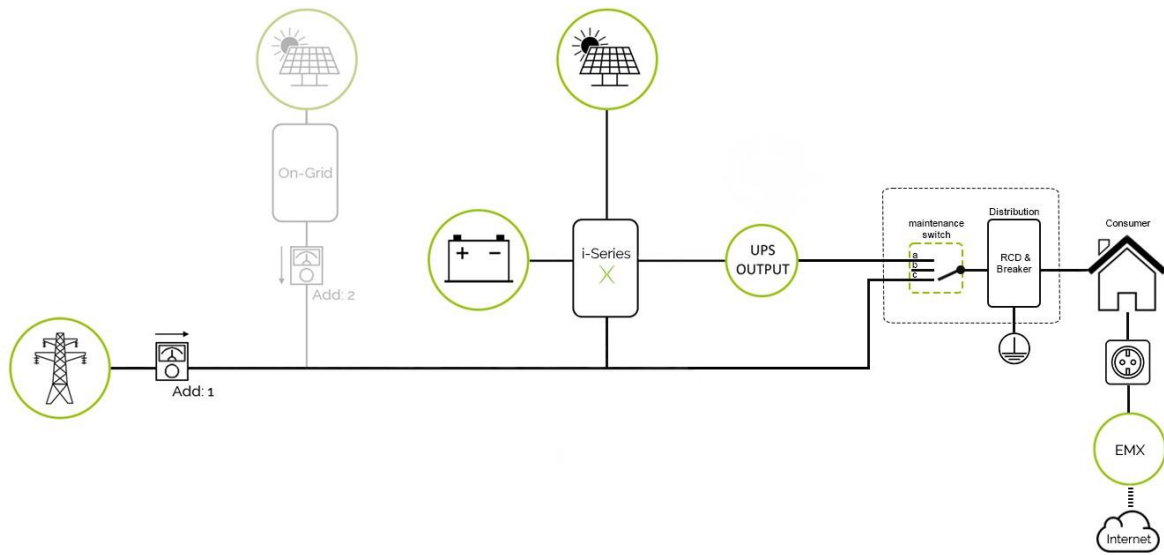

- Caution:** Connect the UPS output to earth, otherwise the installation routine will not run. See section "Commissioning."
- Caution:** The router must also be supplied via the UPS output, otherwise there will be no Internet connection and therefore no monitoring available in the event of a power failure!

Description

By default, the loads are supplied via the mains. In the event of a power failure, the switchover must be carried out manually by switching over the maintenance switch. Caution: Make sure that the connected or switched-on loads do not overload the protected output of the inverter at the moment of switchover. Otherwise, the system will shut down.

By default, the manual switch is set to position c, which means that all loads are supplied from the mains. In the event of a power failure, the manual switch can be set to position a, which means that the loads are supplied from the emergency power output of the inverter. It is essential to ensure that the loads do not overload the emergency power output of the inverter.

Advantage.	Disadvantage
No prior selection of consumers is necessary. In principle, all consumers can be supplied via the protected output, but not simultaneously!	Additional RCD and circuit breaker in meter cabinet/sub-distribution board.
Monitoring is also available in the event of a power failure, provided that manual switching is carried out.	Manual switching is required.
No additional housing for RCD and breaker required.	

I. HYBRID INVERTERS

The hybrid inverters of the i-Series comprise 3 models, which are listed below:

The i10/i20/i30 inverter

APPEARANCE OF THE I10/I20 INVERTER

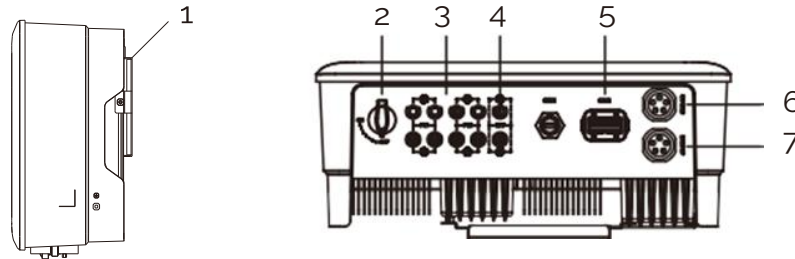

The connection terminals are located on the underside of the inverter, as shown in the table below.

Number	Terminal	Note
1	Suspension bracket	Used to hang the inverter on the wall bracket.
2	DC switch	Used to safely disconnect the DC circuit.
3	DC input terminal	PV plug connector
4	Battery input terminal	Battery connector
5	COM2 connection	Multifunction connector (current meter/BMS/RS485/DRED)
6	Mains input terminal	For connecting the mains cable
7	Emergency power output terminal	For connecting the emergency power output cable

APPEARANCE OF THE I30 INVERTER

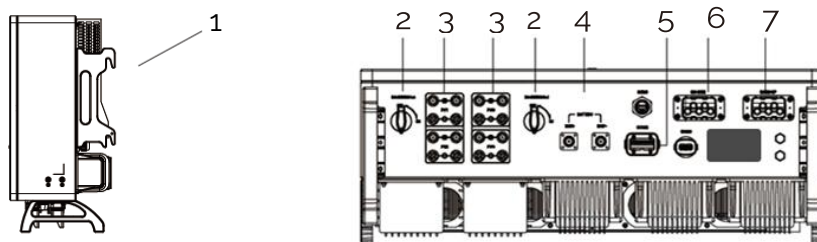

The connection terminals are located on the underside of the inverter, as shown in the table below.

Number	Terminal	Note	
1	Suspension device	Used to hang the inverter on the wall bracket.	
2	DC switch	Used to safely disconnect the DC circuit.	
3	DC input terminal	PV connection (8 pairs)	
4	Battery input terminal	Battery connection	
5	COM2 connection	Digital output counter/BMS/RS485/DRED	
6	Mains output terminal	For connecting the mains output cable	



7	Emergency power output terminal	For connecting the emergency power output cable
---	---------------------------------	-------------------------------------------------

DISPLAY



No	Display	Status	Description	
1	Operating and alarm indicator	Off	No operation.	
		Green	Fast flashing	Inverter in self-test mode.
			Slow flashing	Inverter in standby mode.
			Long flashing	Inverter is working normally.
		Orange	Long flashing	Warning when the battery is low; the battery power will soon reach the state of charge (SOC) protection value.
Red	Steady light	An alarm or error has been detected; refer to the error information on the display.		
2	Power supply indicator	Off	Mains power connection lost.	
		Slow Flashing	The inverter has detected a power grid but is not running in grid mode.	
		Steady light	The inverter is operating in grid mode.	
3	Communication indicator	Green	Steady light	The inverter communication BMS is functioning. No communication with EMX
		Green	Flashing	The inverter is communicating with EMX. Communication is working normally.
		Red	Steady	The inverter is not communicating with the BMS.
4	Display	Display will switch off to save energy; press the button to operate the display.		
5	Button	Switch between display information and set parameters by pressing briefly or holding down the button.		



II. BATTERIES

A. S1 BASE

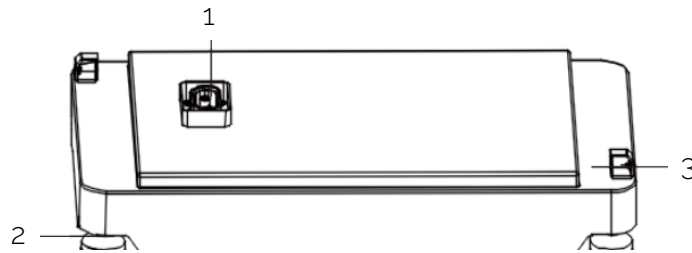

No	Definition	Description
1	Power supply terminal	/
2	Adjustable feet	/
3	Battery compartment (for stacking)	/

B. S1 BAT 2.5

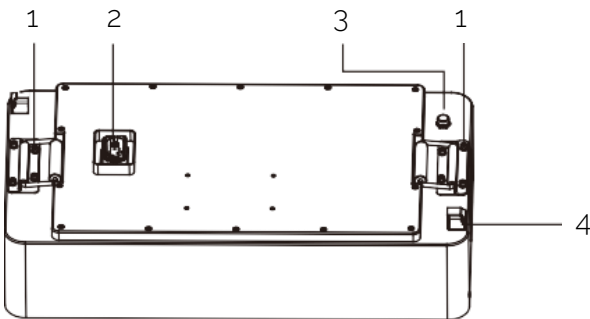

Top view of the battery module

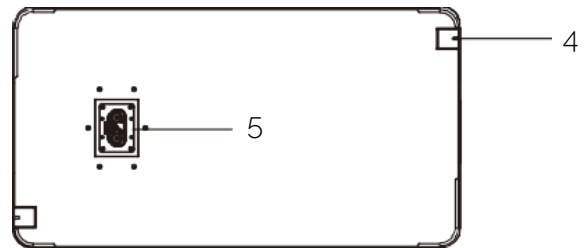

View of the battery module from below

No.	Definition	Description
1	Lifting bracket	For handling the battery module
2	Input of the power supply terminal	/
3	Decompression valves	/
4	Battery slot (for stacking)	/
5	Power supply terminal output	/



C. S1 BMS

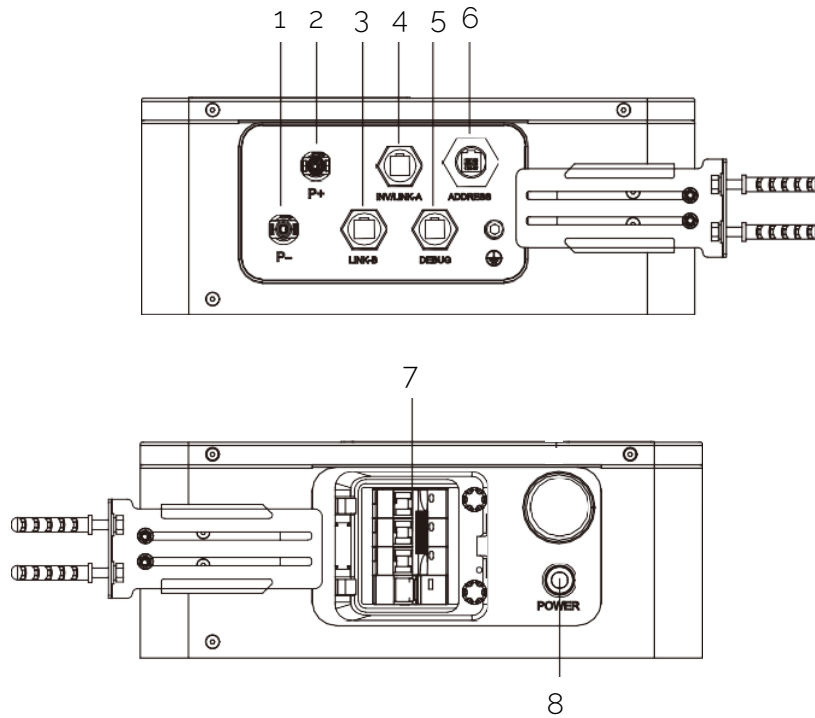

The definition and description of the controller connections are shown below:

No	Definition	Description
1	P-	Battery negative terminal
2	P+	Battery positive terminal
3	LINK B	Connection for parallel battery connection
4	LINK A/INV	Communication connection of the inverter (Connection for parallel battery connection)
5	DEBUG	Service port used for upgrades, data export, etc.
6	ADDRESS	Set address for each tower when using MULTI
7	Switch/breaker	Battery circuit breaker
8	Button/LED	Switch the battery on/off. Status display of the battery tower

D. S1 MULTI

The MULTI is only required if several battery towers are connected in parallel. A maximum of 3 battery towers can be connected in parallel. If the system is only equipped with one battery tower, please skip this section.

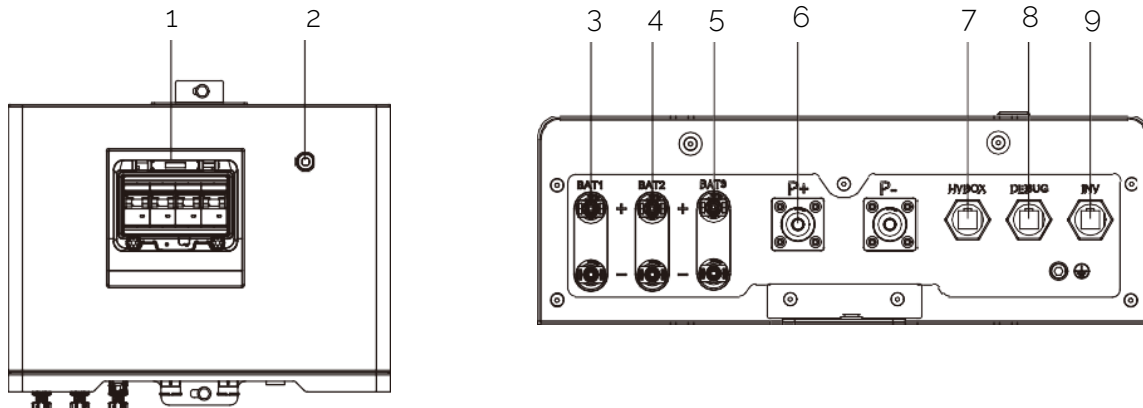

No.	Definition	Description	
1	Breaker/switch	Circuit breaker for switching the MULTI on and off	
2	Push button (latching)/LED	On/off switch and status indicator	
3	BAT1	+	Connection for the 1st battery tower
		-	
4	BAT2	+	Connection for the 2nd battery tower
		-	
5	BAT3	+	Connection for the 3rd battery tower
		-	
6	P+	Connections for the inverter	
	P-		
7	HVBOX	Communication connection for battery tower	
8	DEBUG	Service port used for upgrades, data export, etc.	
9	INV	Communication port for the inverter	

STATUS DISPLAY OF THE S1 MULTI

The status of the power supply indicator and the corresponding explanations are shown below:

No	Display	Description
1	Off	The battery is switched off.
2	Alternating green and red flashing	The breaker switch is turned on and the battery is waiting for the self-checking mode to start.
3	Continuous green	Normal operation or debugging
4	Flashing green	Self-checking is performed
5	Continuous red	Battery alarm. In a parallel system (multiple battery towers), the MULTI display lights up red when the breaker switch of a battery tower is triggered and the remaining batteries are running normally or are in debugging mode.
6	Red flashing	The battery has a fault that requires attention.



III. EMX

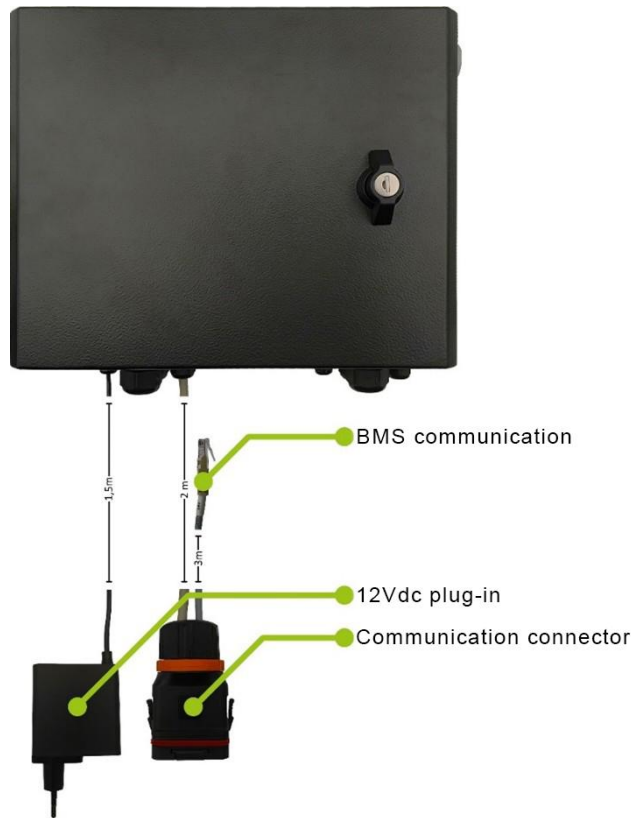

BMS communication: Communication between the inverter and the battery management system.

12Vdc plug-in power supply: Power supply for the EMX. The socket used must be supplied by the backup output of the inverter.

Communication connector: The communication connector of the i-Series inverters includes RS485 Modbus communication between the EMX and the inverter.

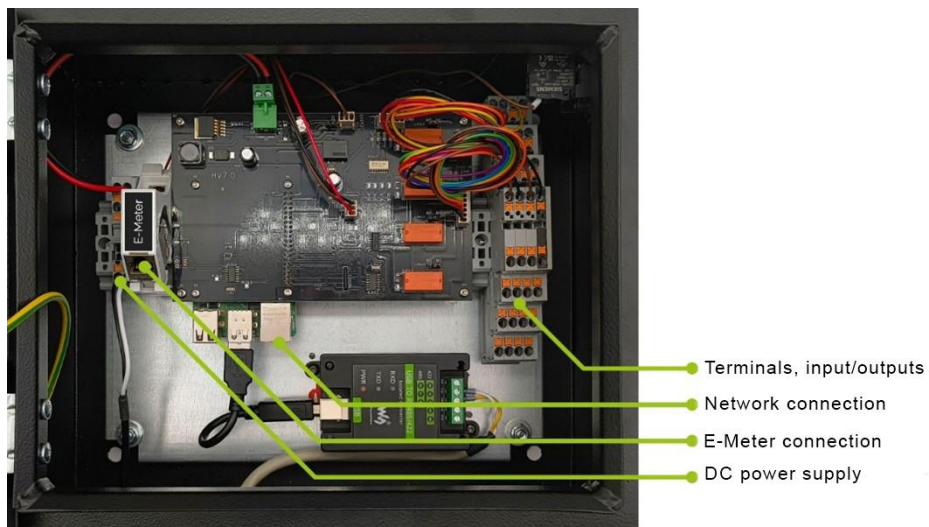

DC power supply: Plug the wires of the 12VDC power supply into the pluggable part of the terminal. Make sure to observe the polarity and plug it into the socket of the feed-through terminals on the DIN rail.



Caution! Reversing the polarity of the supply voltage can damage the circuit board/PCB!



Terminals, inputs/outputs: Terminal connection of the freely programmable inputs/outputs. The outputs are potential-free contacts. The inputs can be activated by potential-free contacts.



The black terminal (far right) is single-pole, meaning that all connections on this terminal are connected to each other.

Network connection: Network interface to a network connected to the Internet. The network cable is not included in the scope of delivery and must not exceed 30 m in length (Cat. 6 or higher).

E-meter connection: Interface to the E-meter at the grid feed-in point, which is included with the i-Series inverter. If a cable other than the one supplied is used, it must not exceed a length of 30 m.



Signal light: There is a signal light on the upper right side of the EMX that indicates that the EMX is powered and switched on.



Cable entries: There are several cable entries on the underside of the EMX, two of which are already occupied by pre-installed cables. The two remaining entries on the left side are specifically intended for the network cable and contain a slotted seal. This allows a cable with a prefabricated plug to be used.

All cable entries on the right side are intended for use with the inputs and outputs. These are fitted with sealing plugs when delivered, which can be removed when in use. The types and number of cable glands are listed below:

- 1x M12, clamping range 3.5-7 mm \emptyset
- 2x M16, clamping range 4-10 mm \emptyset
- 2x M25, clamping range 8-17 mm \emptyset

IV. E-METER

The installation of the i-Series always includes at least one E-meter. A more detailed description of the installation and cabling can be found in the relevant chapters of this manual.

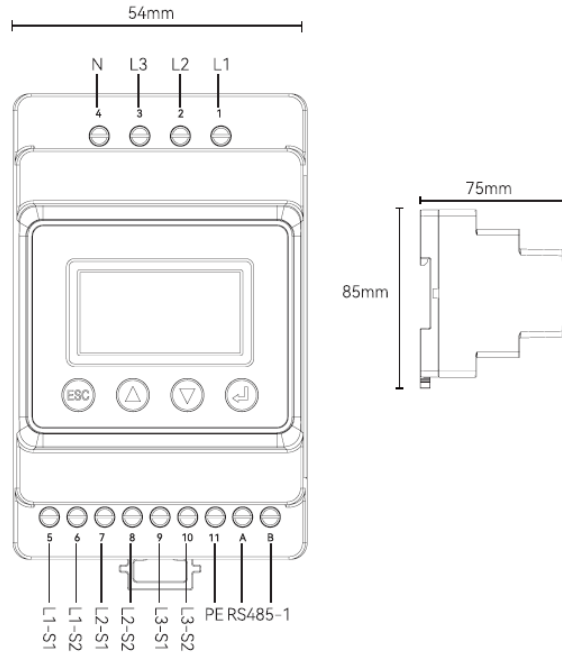

4. INSTALLATION

I. HYBRID INVERTER

The hybrid inverters of the i-Series are designed for wall mounting. Please observe the minimum distances to ensure adequate heat dissipation.

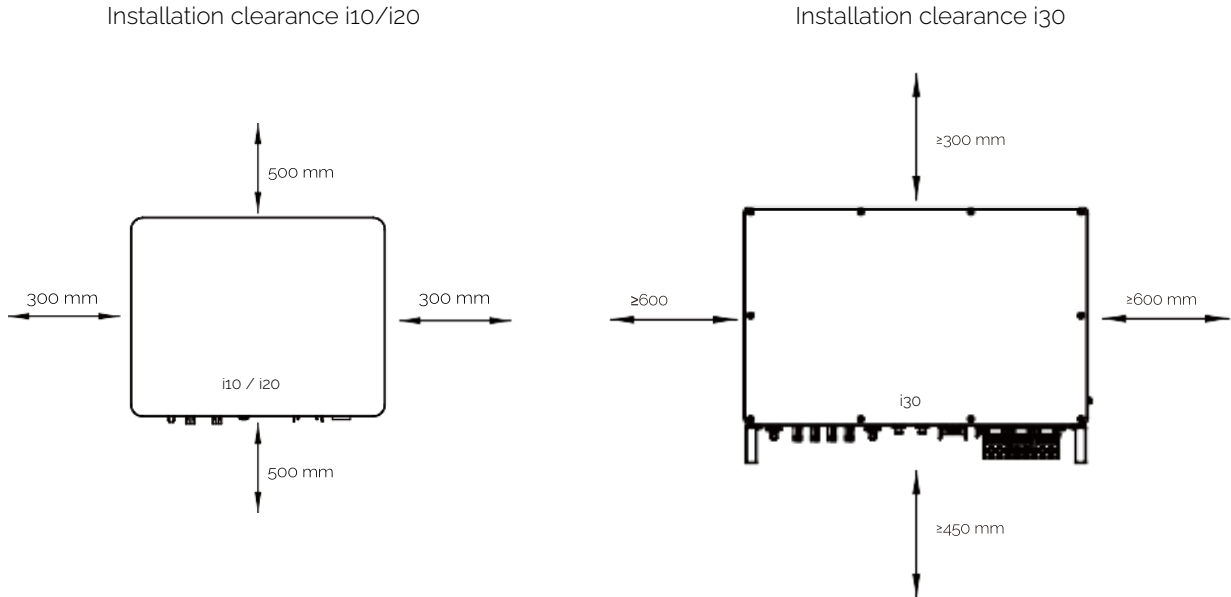

Mount the inverter vertically. Never mount the inverter horizontally, tilted forward/backward, or upside down.

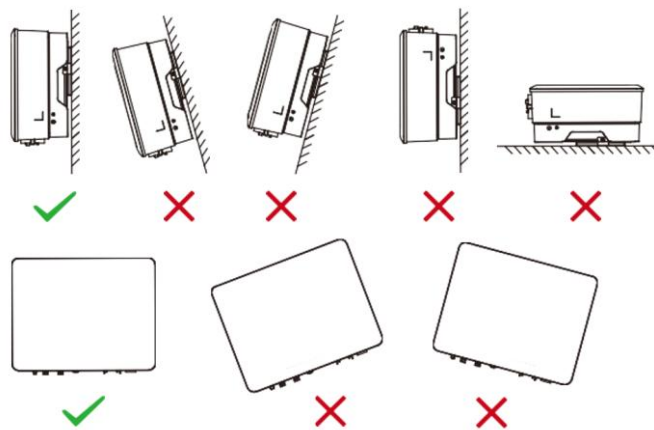

MOUNTING THE WALL BRACKET FOR THE I10/I20

Dimensions of the wall bracket in mm.

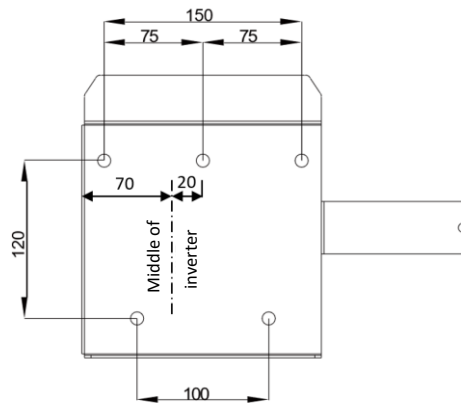

Use the wall bracket as a template to mark the position of the 5 holes on the wall.

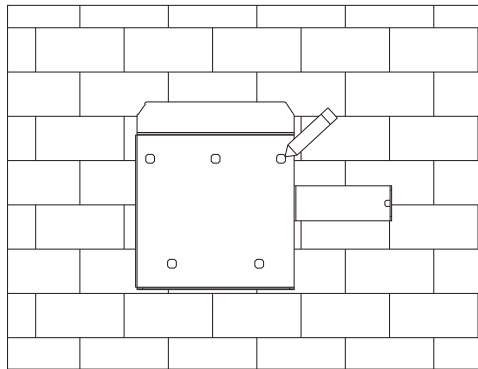

Drill five 80 mm deep holes in the wall using an electric drill and a 10 mm drill bit.



Before drilling, make sure that there are no water or electrical lines in the wall.

Insert the wall plugs into the holes, then secure the bracket to the wall using a Phillips screwdriver and screws.

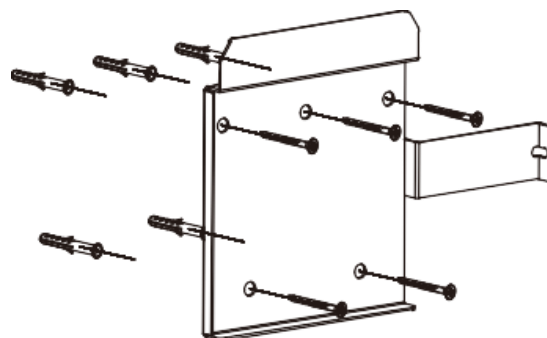

MOUNTING THE WALL BRACKET FOR THE I30

Dimensions of the wall bracket in mm.

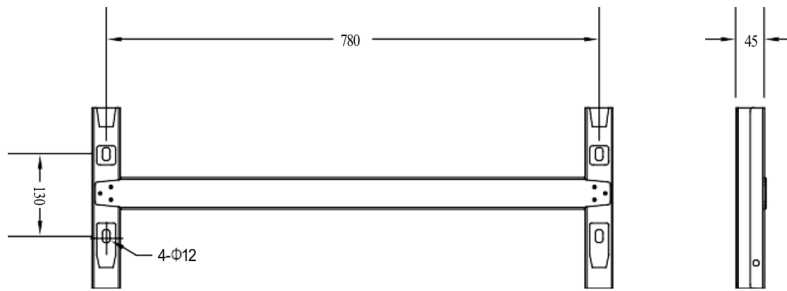

Align the assembled inverter bracket horizontally using a spirit level and mark the positions for the holes through the bracket. Drill the holes with a hammer drill.



Before drilling, make sure that there are no water or electrical lines in the wall.

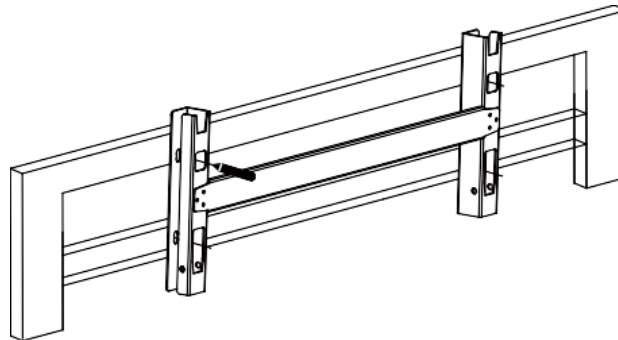

Secure the inverter bracket with screws.

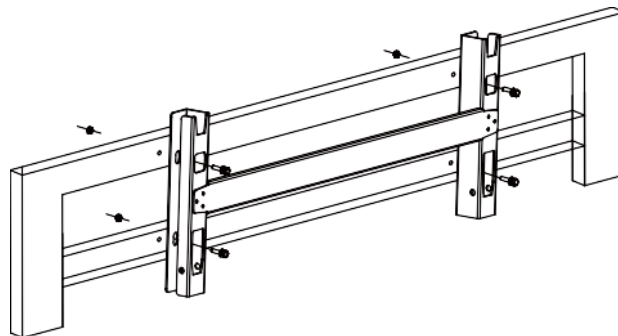

MOUNTING THE I10/I20 INVERTER

Lift the inverter and carefully hook the rear rail into the fixed wall bracket. Secure the inverter with M5 screws.

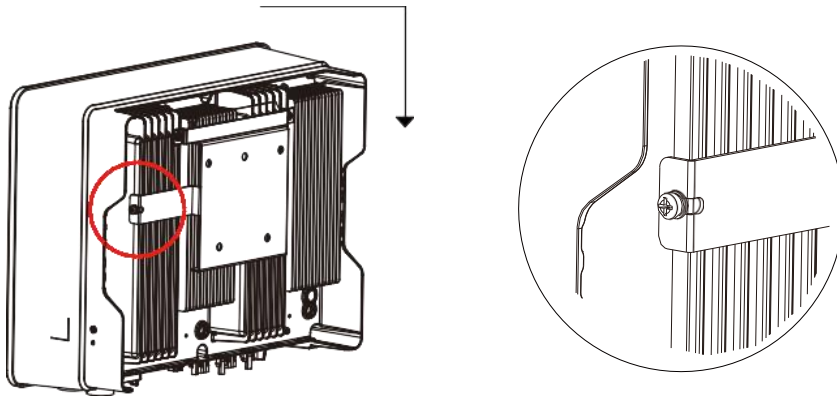

INSTALLING THE I30 INVERTER

Lift the inverter and carefully hook the rear rail into the fixed bracket. Secure the inverter with M6 screws (both sides).

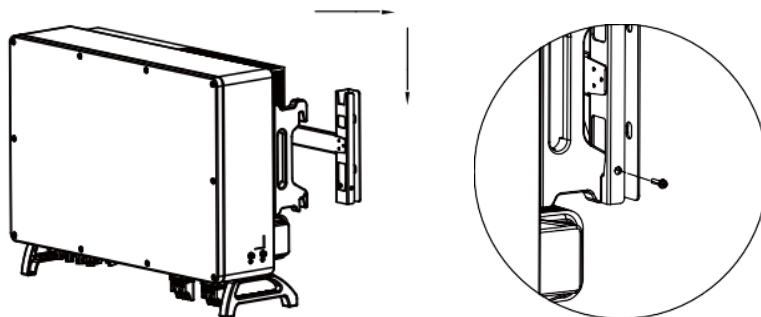

II. BATTERIES

The installation of the various components of a battery tower is explained below. If you are using multiple battery towers, please refer to the "MULTI" section.

A. S1 BASE

1. Check the installation environment to ensure that the floor is level. Place the base on the floor and make sure that it is level and stable by adjusting the feet of the S1 BASE.

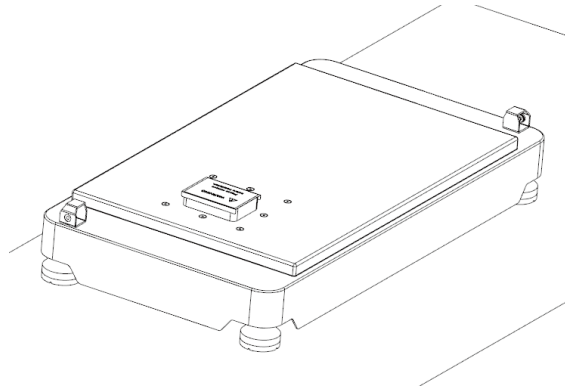

2. The distance between the BASE and the wall is 20 mm – 120 mm.

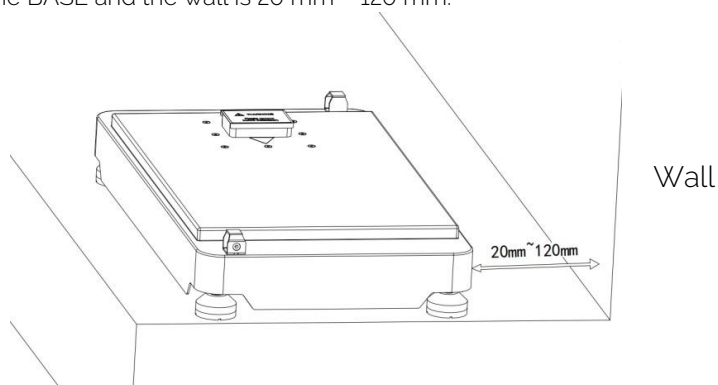

3. Remove the dust-proof label from the power supply terminal.

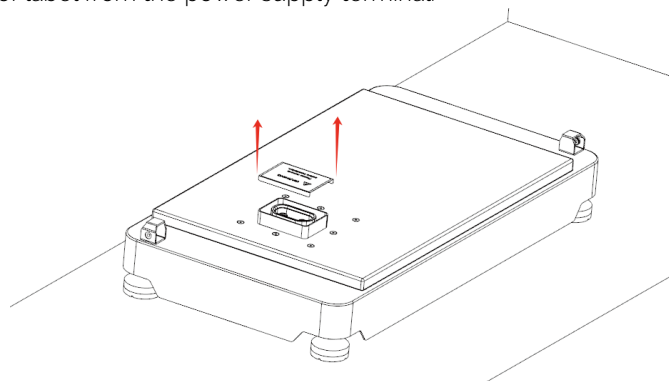

B. S1 BAT 2.5

1. Remove the dust-proof label from the power supply terminal.

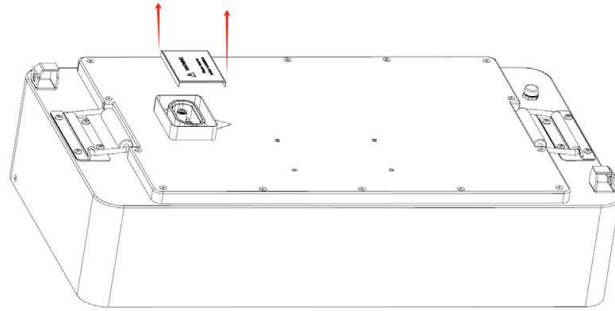

2. Place the battery modules one after the other on the base, making sure that the power supply connections of all battery modules and the base are on the same side.

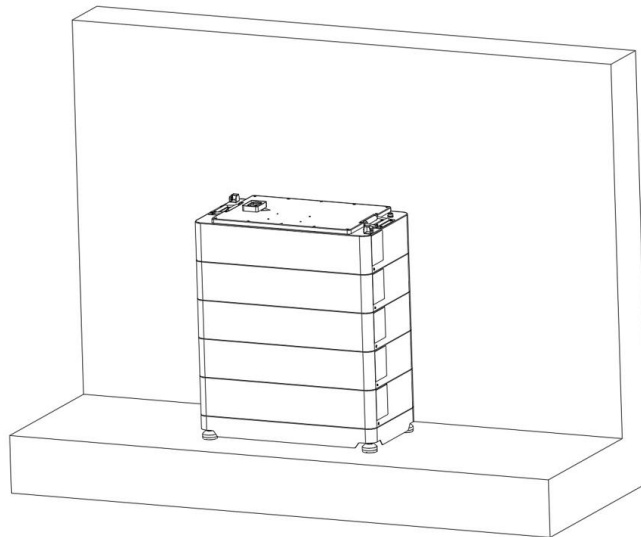

C. S1 BMS

1. Place the BMS module on top of the stacked battery modules.

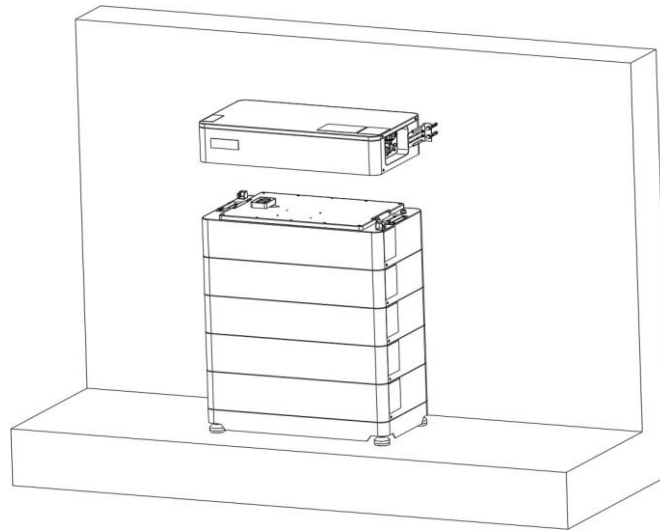

2. Mount the brackets for the BMS module on both sides.

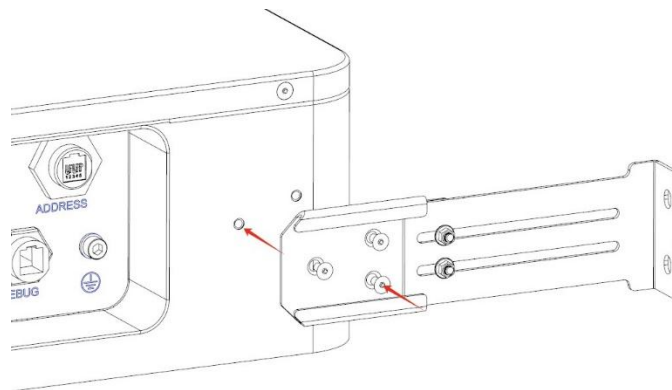

3. Mark the position of the 4 holes to be drilled on the wall.

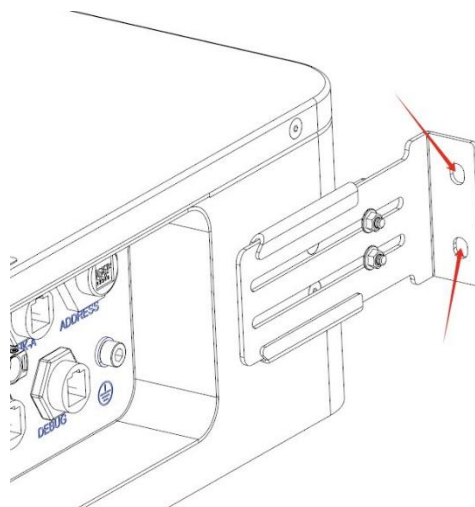

4. Remove the BMS module.

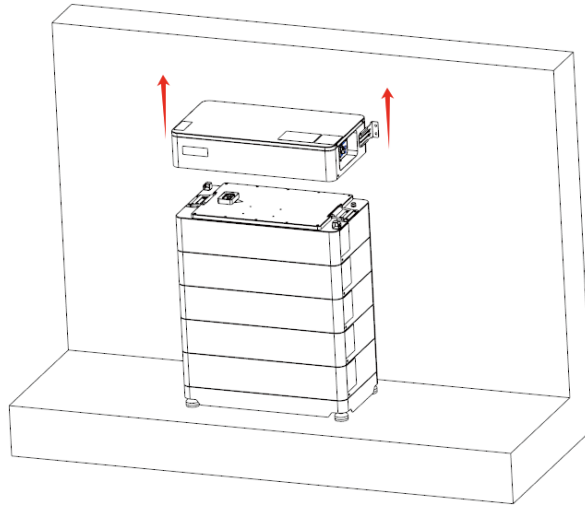

5. Use a $\varnothing 8$ drill bit for the 80 mm deep wall hole and insert wall plugs.



Before drilling, make sure that there are no water or power lines in the wall.

Depth: 80 mm

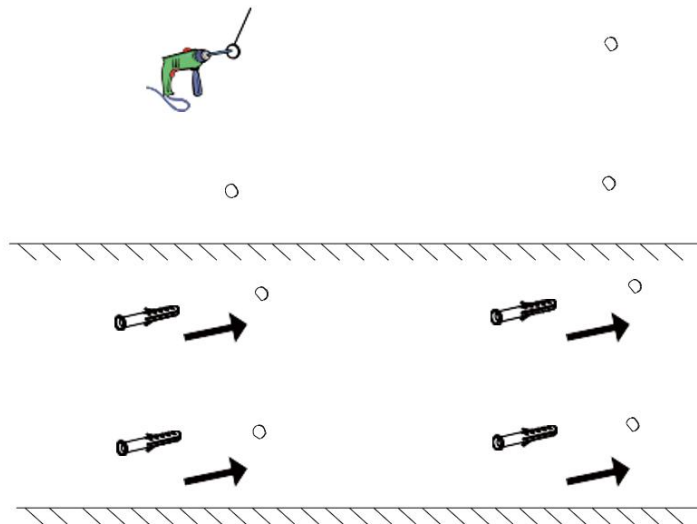

6. Place the BMS module on the battery modules.

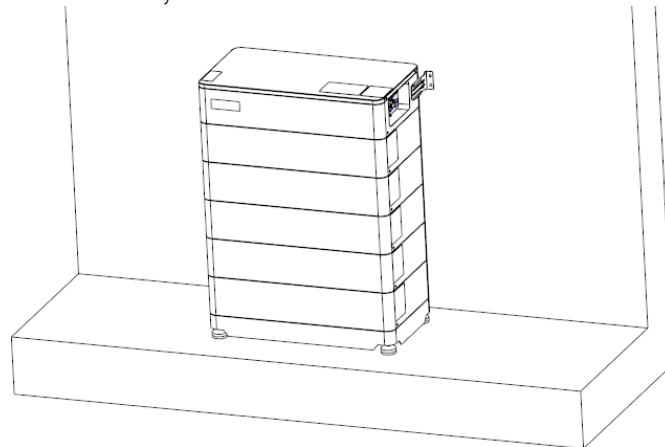

7. Tighten all M4*12 countersunk screws on both sides of all battery modules and the BMS module.

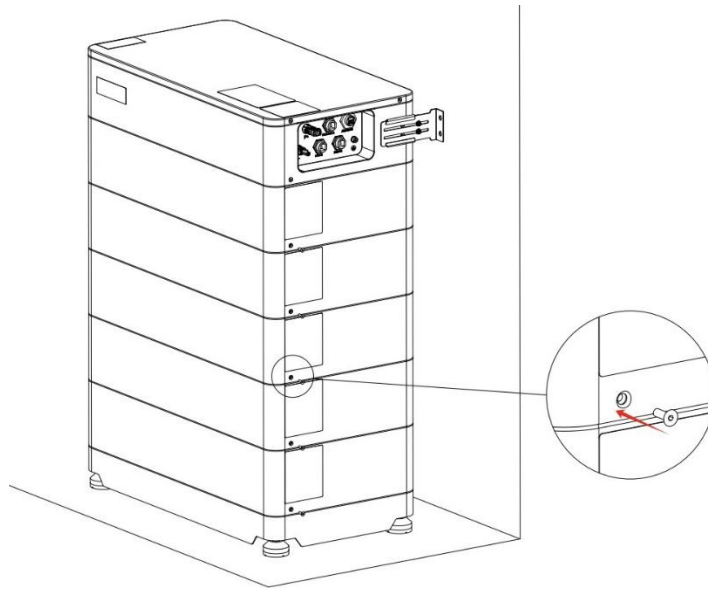

8. Insert the mounting screws into the wall plugs and secure the brackets to the wall with the mounting screws using a wrench.

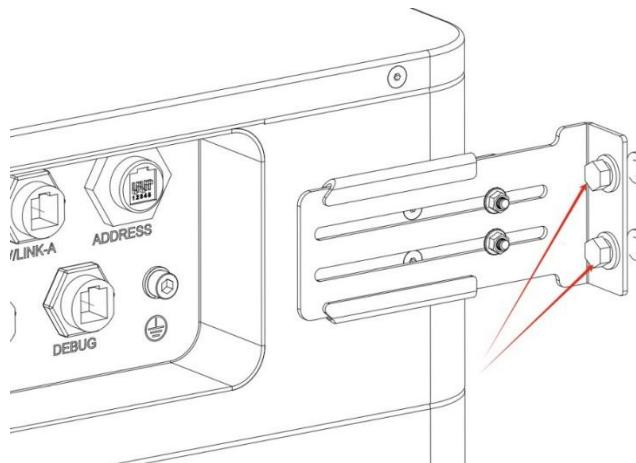

9. Tighten the adjusting screws with a wrench to secure the battery to the wall.

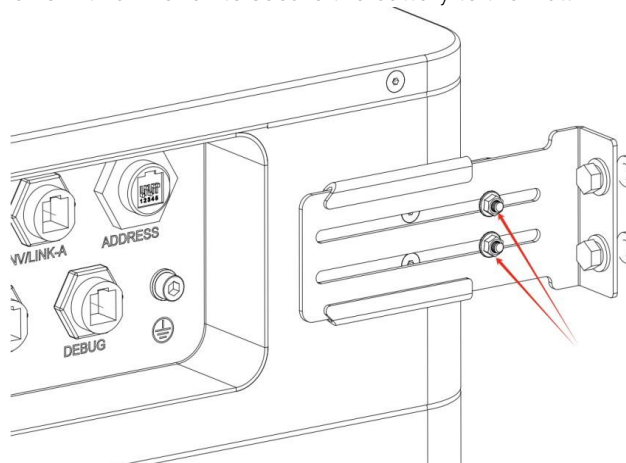

D. S1 MULTI

1. Select a suitable location for the MULTI depending on the location of the battery tower or towers.

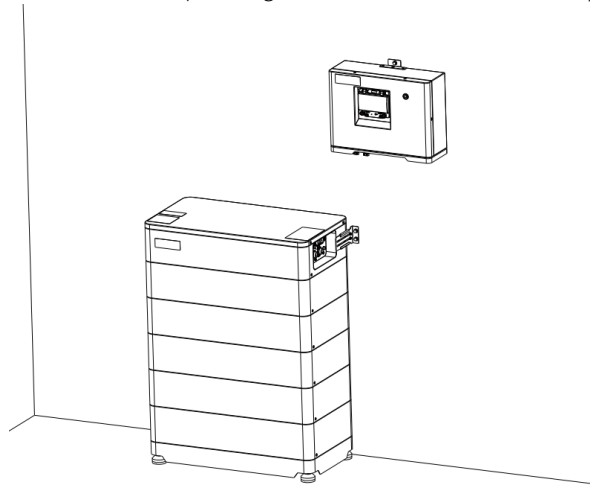

2. Mark the position of the 2 holes to be drilled in the wall.

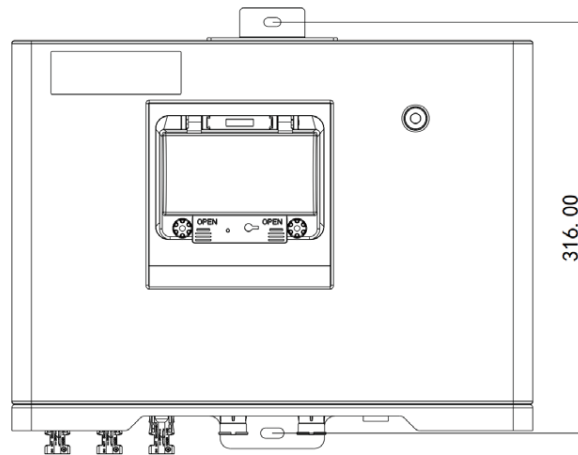

3. Use a $\varnothing 8$ drill bit for the 80 mm deep wall hole and insert the wall plugs.

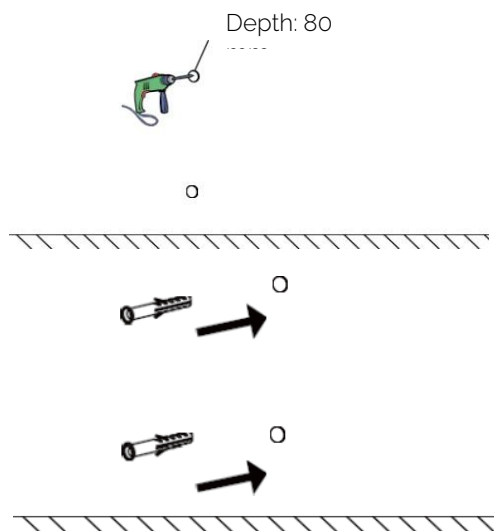

Before drilling, make sure that there are no water or power lines in the wall.



4. Insert the mounting screws into the wall plugs and secure the MULTI to the wall using the mounting screws and a Phillips screwdriver.

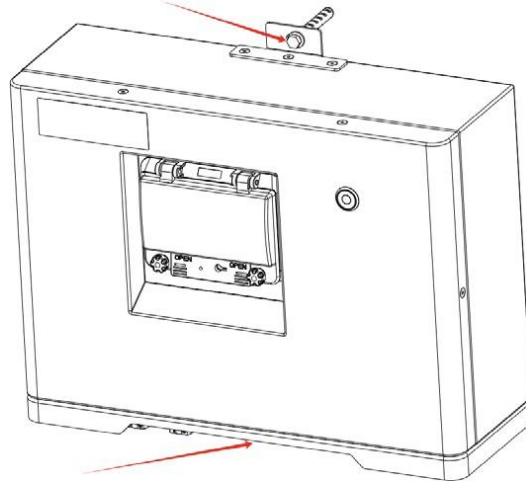

III. EMX

 Before drilling, make sure that there are no water or power lines in the wall.

Select a suitable location for the EMX depending on the location of the battery tower or towers (MULTI if applicable). The EMX is secured to the wall using the 4 screws provided.

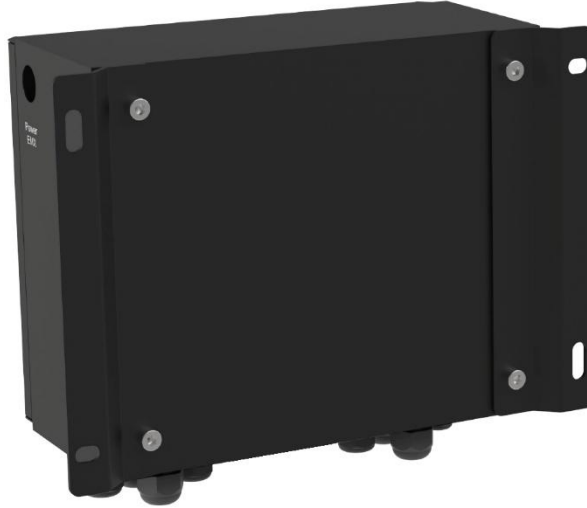

Drill 4 holes (Ø8mm, 50mm deep) and insert the 4 wall plugs supplied, before inserting and tightening the 4 screws. The EMX is now completely and securely attached to the wall.

IV. E-METER

The electricity meter (= E-Meter) is installed at the feed-in point of the electrical installation, usually directly after the energy supplier's meter. The current transformers are usually installed between the house consumers and the power grid. The current transformers cable has a fixed length of 2 m and cannot be extended. The communication connection must be established between the E-Meter and the EMX. If an external on-grid inverter is to be integrated into the portal, it can be recorded using an additional energy meter. To do this, it must be assigned the correct address.

- Feed-in point → Address 1
- On-grid inverter, surplus feed-in → Address 2
- On-grid inverters, full feed-in inverters → Address 3

! External inverters cannot be limited by our portal. Only the excess energy from a surplus feed-in device can be used to charge the battery.

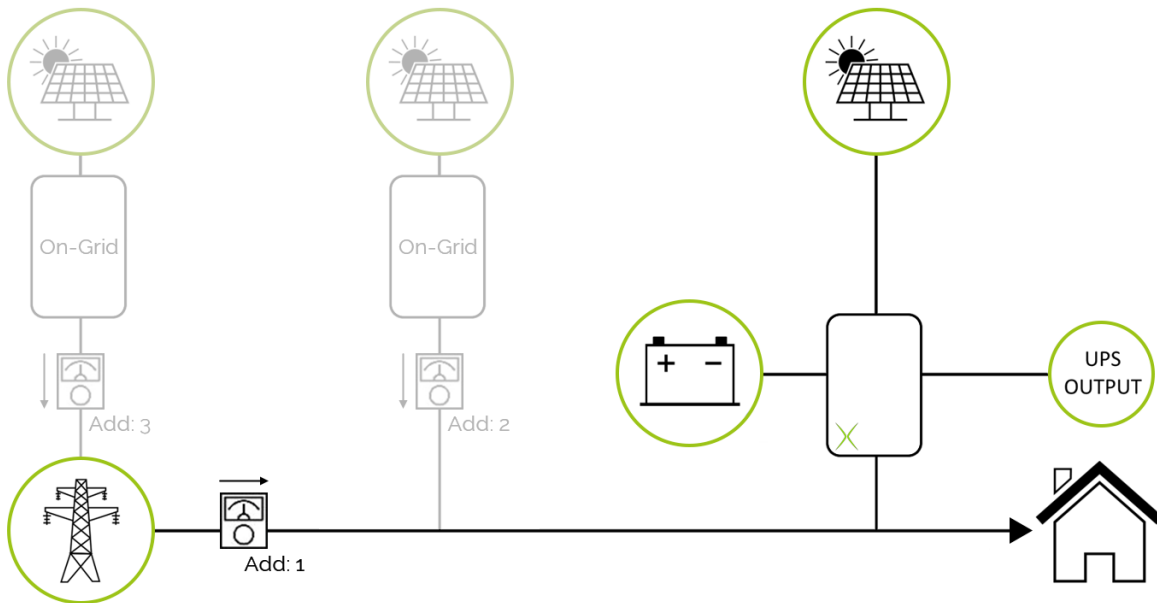

INDIRECT MEASUREMENT

In indirect measurement, the current to be measured flows through current transformers connected to the energy meter. These current transformers have a split core so that the cable for installing the transformers does not need to be disconnected. The E-meter must also be connected to a reference voltage and power supply. The coils supplied are matched to each individual E-meter. The coils must not be replaced by others, as this may cause problems. Shortening or extending the cables is also not permitted.

INSTALLATION ON A DIN RAIL

To install on a DIN rail, pull down the small plastic lever on the underside of the E-meter. You can then place it on the DIN rail. To secure it, press the small plastic lever on the underside back up. The E-meter should now be unable to move sideways.

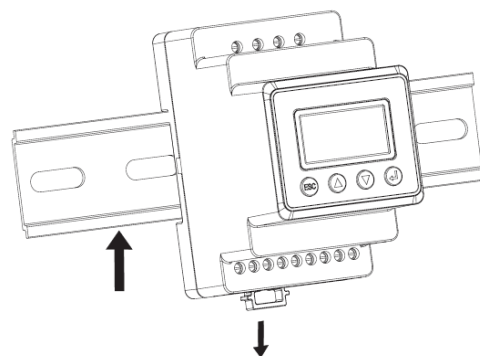

5. WIRING

! All electrical installations must comply with local electrical safety regulations. Please ensure that the correct fuse or circuit breaker is selected!

I. HYBRID INVERTER

I10 & I20

This circuit diagram shows the structure and layout of the i10/i20 hybrid inverters. In the actual project, the installation and wiring must comply with local regulations.

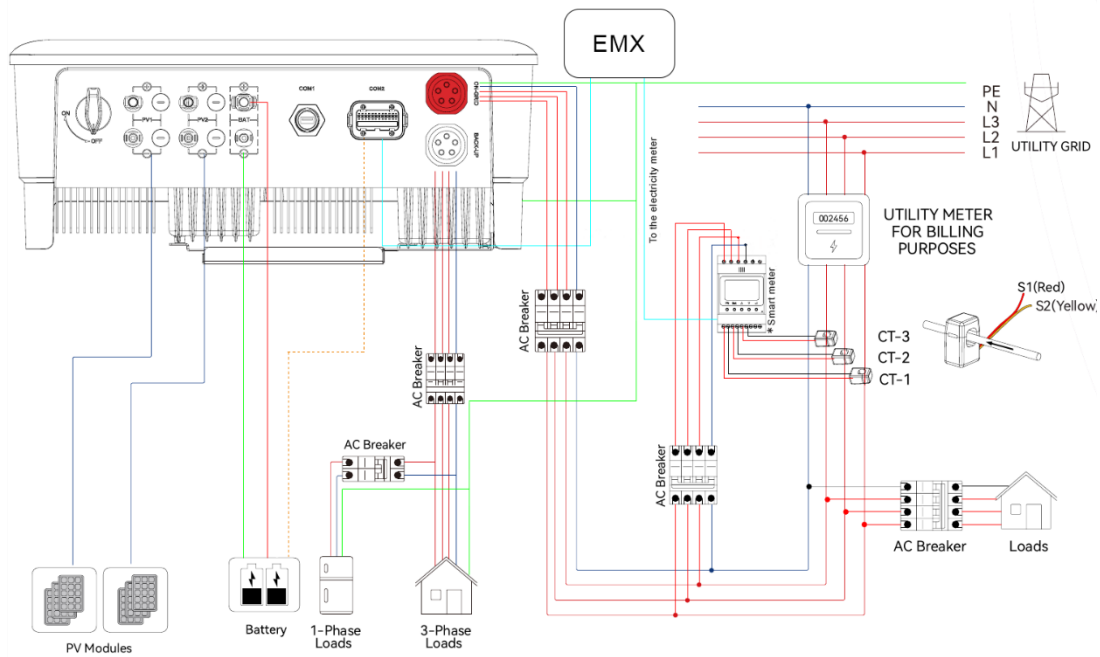

CIRCUIT DIAGRAM FOR A SINGLE INVERTER

This circuit diagram is an example without any special requirements for electrical wiring. Please observe local regulations, laws, and requirements in all cases! The following connection is a suggestion and only applies to TN-C, TN-S, and TN-C-S networks.



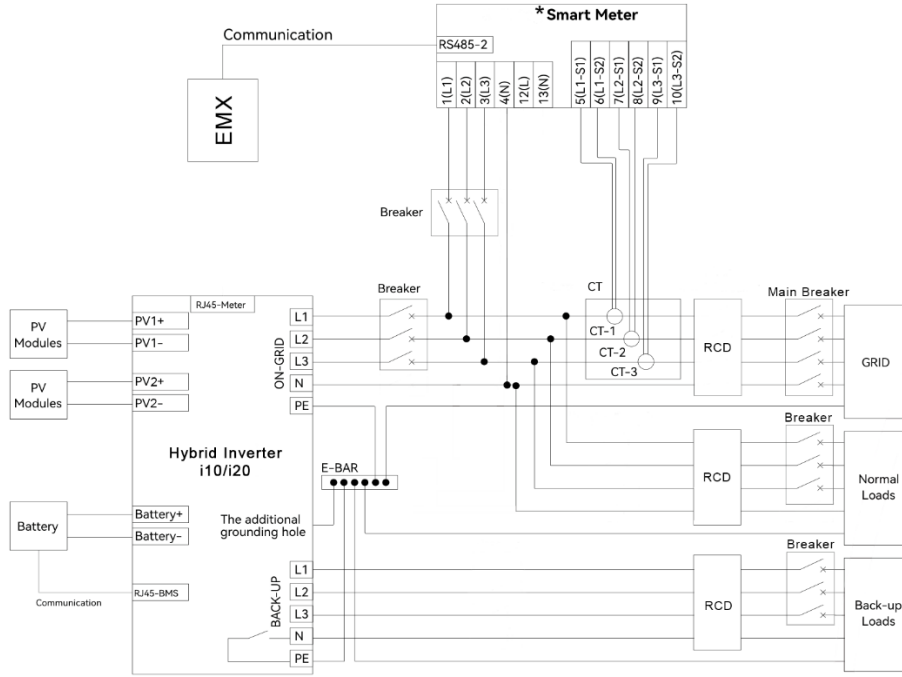

The following connection is a suggestion and only applies to TT networks.

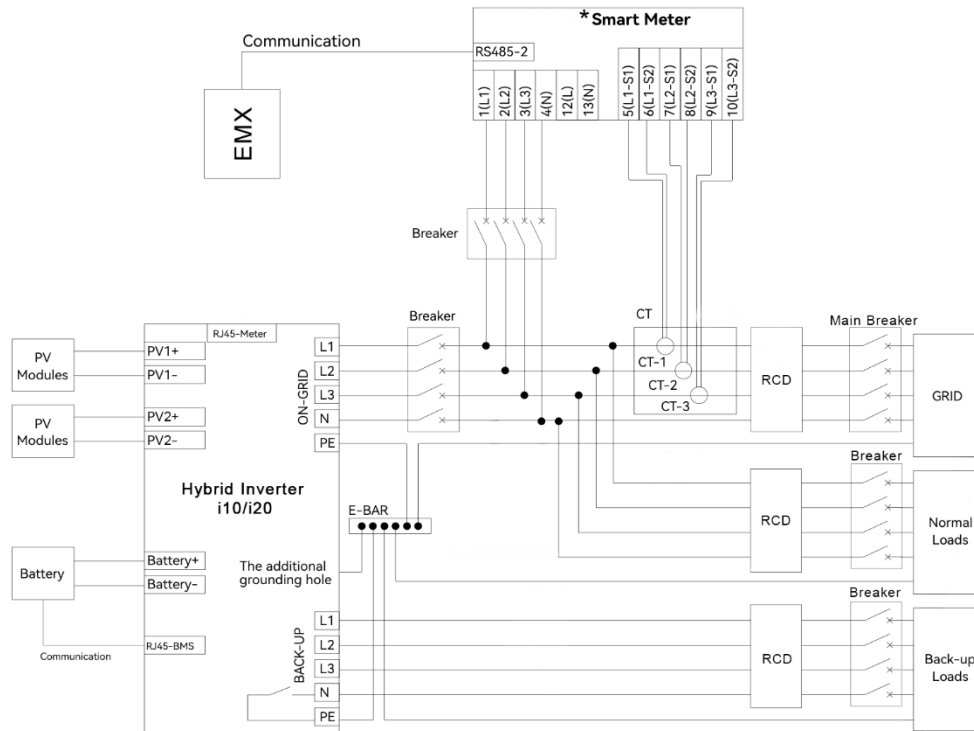

GROUNDING

Connect a suitable grounding cable (potential equalization) to the bottom of the inverter. Observe local regulations!



The following connection is a suggestion and only applies to TT networks.

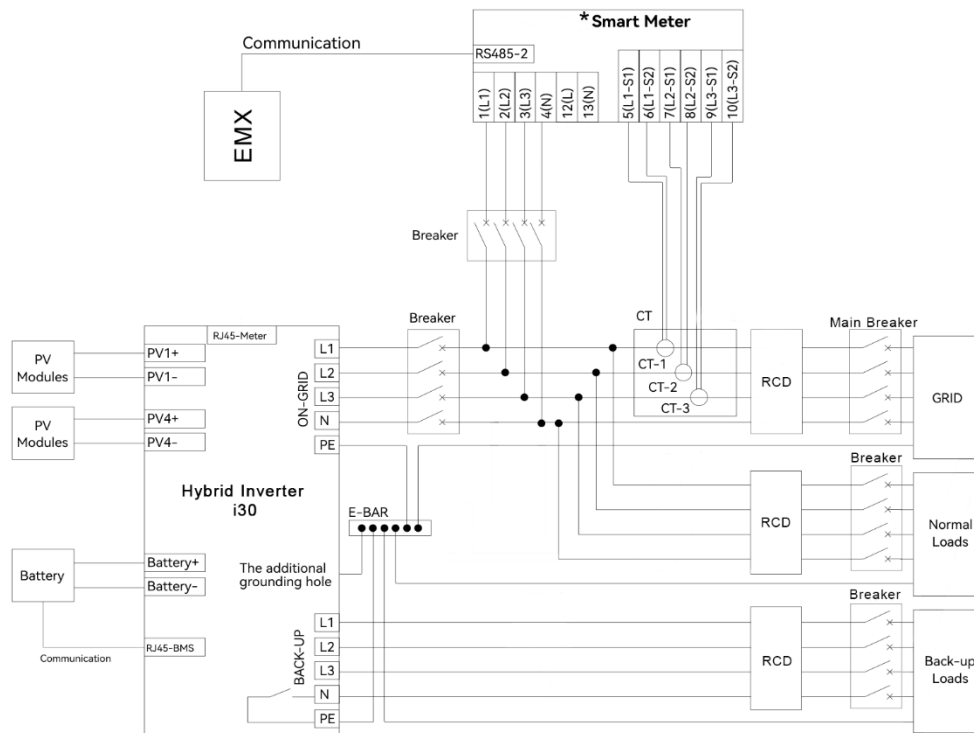

GROUNDING

Connect a suitable grounding cable (potential equalization) to the bottom of the inverter. Observe local regulations!



An independent AC circuit breaker is required on both the mains and emergency power output sides, and no loads may be connected directly to the inverter. Before connecting the AC cable, make sure that all AC and DC power sources are disconnected from the inverter. The three-phase hybrid inverter of the i-Series is suitable for a three-phase power grid with a voltage of 230/400 V and a frequency of 50 Hz. Only connect the inverter to the power grid after approval by the public power supply company.

A three-phase AC circuit breaker must be installed on the AC side of the inverter. To ensure that the inverter is safely disconnected from the power grid in exceptional cases, select a suitable overcurrent protection device in accordance with local regulations and the maximum input (output) current on the AC side of the inverter.

The permissible AC cable diameters and cross-sectional areas are listed below:

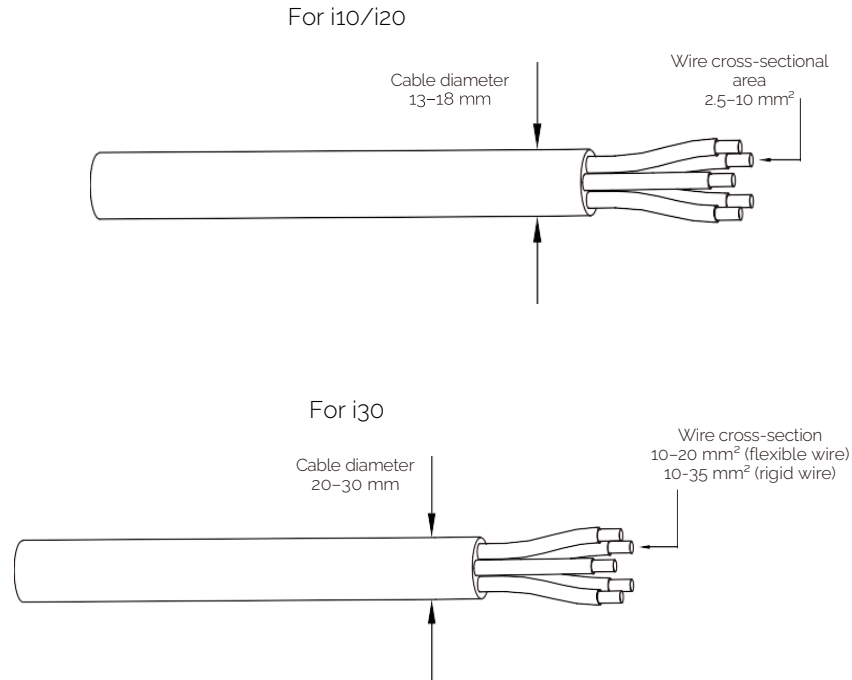

Determine whether an AC circuit breaker with a higher overcurrent capacity is required based on the actual conditions.

FAULT CURRENT MONITORING DEVICE

Thanks to integrated universal residual current monitoring, the inverter disconnects immediately from the grid as soon as a residual current exceeding the limit value is detected.

We recommend installing a residual current circuit breaker (RCCB) at the input of the inverter (see wiring diagram). We recommend connecting a type A 30 mA residual current circuit breaker (RCCB) downstream. Selectivity must be ensured if necessary. In any case, local laws and guidelines must be observed. Legal requirements take precedence over our recommendations.

ASSEMBLY AND CONNECTION OF THE AC PLUG CONNECTOR, i10/i20

The AC connections are located on the underside of the inverter.

- Take the AC connector out of the accessory bag and take it apart.

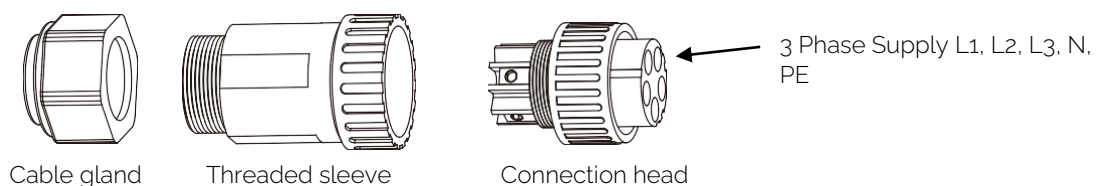

- Select a suitable cable, strip the insulation from the AC cable sheath to a length of 50 mm and strip the end of the 3L/PE/N conductor to a length of 8 mm.

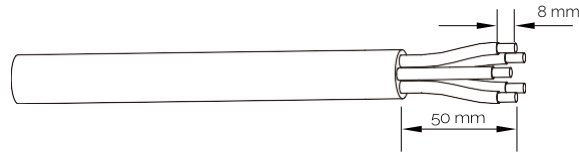

- Insert the stripped ends of the five conductors into the corresponding holes in the connection head and tighten the screw with a torque of 2 Nm (± 0.2). Try to pull the cable out to ensure that it is securely connected.

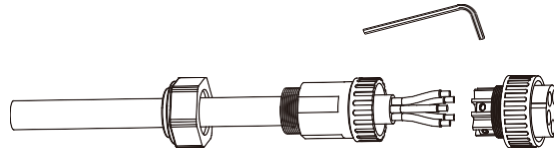

! The screw connections must be tightened securely to ensure that they do not come loose even after prolonged use.

- Press the threaded sleeve in the direction of the arrow to connect it to the connection head, then turn the cable gland clockwise to lock it.

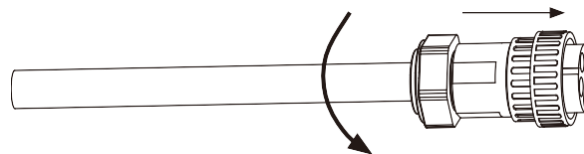

! High voltage may be present in the inverter! Before making any electrical connections, make sure that all cables are de-energized. Only switch on the AC line circuit breaker once all electrical connections to the inverter have been made.

Connect the AC plug connector to the AC connection of the inverter and turn the screw connection of the AC plug connector clockwise until it is tight enough.

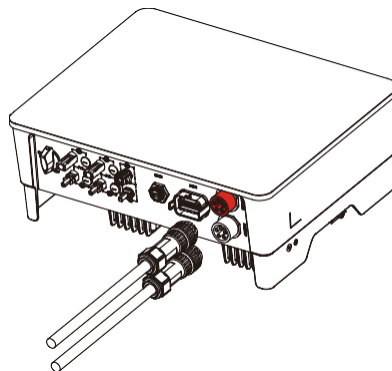

! Please note the difference between the mains connection and the emergency power connection and do not confuse the two connections when making the connection.

ASSEMBLING AND CONNECTING THE AC PLUG CONNECTOR, I30

The AC connections are located on the underside of the inverter.

- Optional sealing accessory. The recommended outer diameter of the cable is 20–24 mm and 24.5–30 mm. If the outer diameter of the cable is greater than 24 mm, remove part 1.

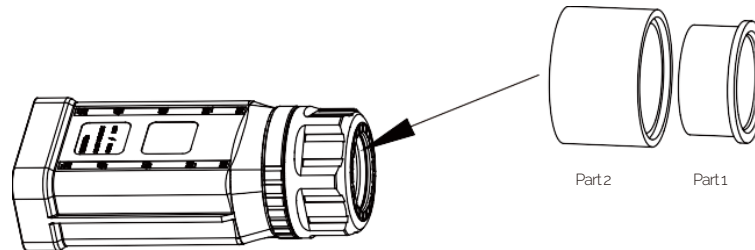

- Select a suitable cable, strip the sheath of the AC cable 95–100 mm away and strip the end of the 3L/PE/N conductors 15 mm away.

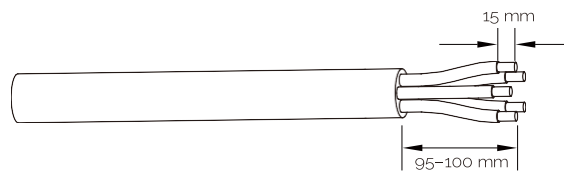

- First thread the stripped cable through the lock nut and then into the main housing (the multi-core copper stranded cable must be fitted with ferrules).

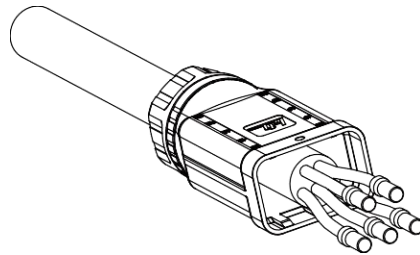

- Insert the cable into the rubber core according to the conductor's sequence and pay attention to the viewing hole. Once the cable is in place, tighten the terminal with a screwdriver and a tightening torque of 4 Nm (± 0.3).



The screw connections must be tightened securely to ensure that they do not come loose even after prolonged use.

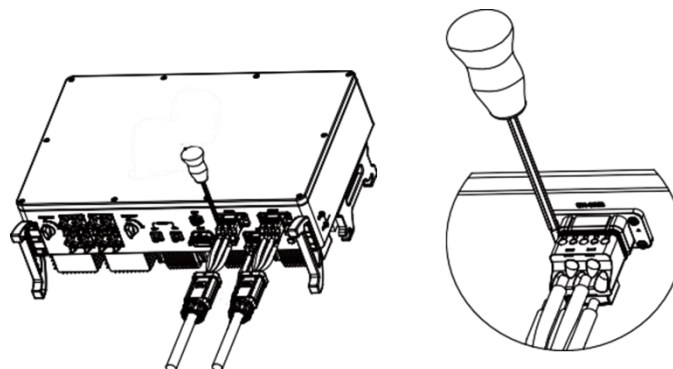

- Insert the main housing into the rubber core and listen to the "click" sound. Then tighten the nut with a flat-head screwdriver (torque 10.0 \pm 0.1 Nm).

REMOVING THE AC CONNECTOR

- Hold the release with one hand and turn it in the marked direction, then turn the nut in the opposite direction with the other hand.
- Align the release position with a screwdriver, then press and hold the main housing and pull it backward to remove the connector.

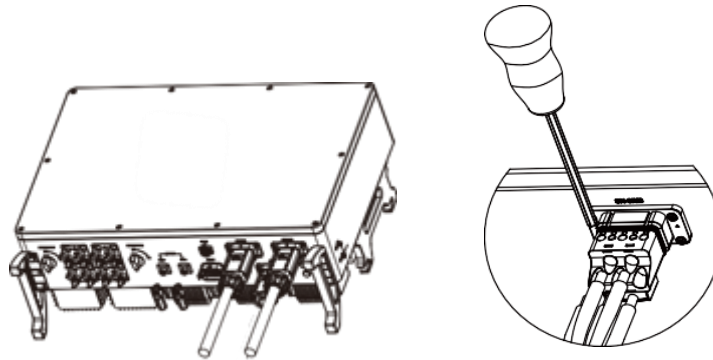

Please note the difference between the mains connection and the emergency power connection and do not confuse the two connections when making the connection.

COMMUNICATION CONNECTION

All communication connections are located in the multifunction communication port (COM2 connector) on the bottom of the inverter, including the power meter connection, CAN connection, BMS connection, and EMX connection. The connector is supplied pre-wired with the EMX.

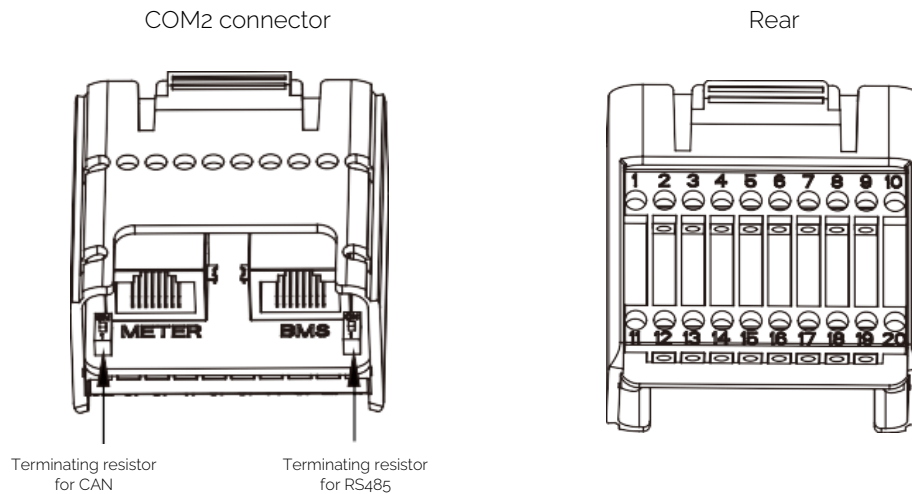

Pin	Definition	Function
METER (RJ45-1)	RS 485	Communication with the electricity meter
BMS (RJ45-2)	CAN	Communication with BMS
11*	Emergency Stop +	Emergency Stop, NO/NC selectable
12*	Emergency Stop -	
13	485 B1	EMX
14	485 A1	



ASSEMBLING THE COM2 CONNECTOR

The connector will be delivered pre-wired. The following explanations are provided for better understanding. Unscrew the cap nut from the connector. Remove the terminal strip.

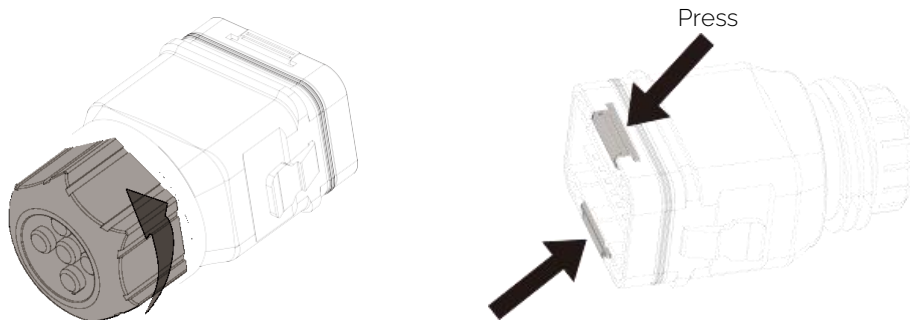

Remove the seal and feed the cable through the cable gland.

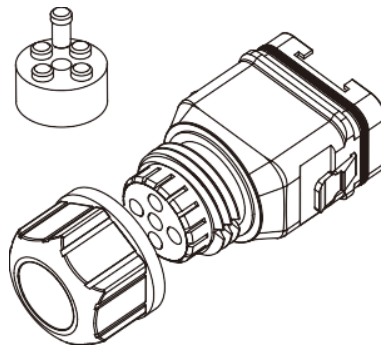
**CONNECTING THE COMMUNICATION CABLES FOR THE ELECTRICITY METER AND BMS**

Communication with the E-meter is via the EMX. The connection between the BMS and the inverter is made via an RJ45 interface cable, which is pre-wired in the COM2 connector together with the EMX.

Plug the other end of the communication cable into the CAN port of the BMS.

ATTACHING THE COM CONNECTORS

Remove the waterproof cover from the COM terminal. Plug the COM connector into the COM terminal on the underside of the inverter until you hear an audible click.

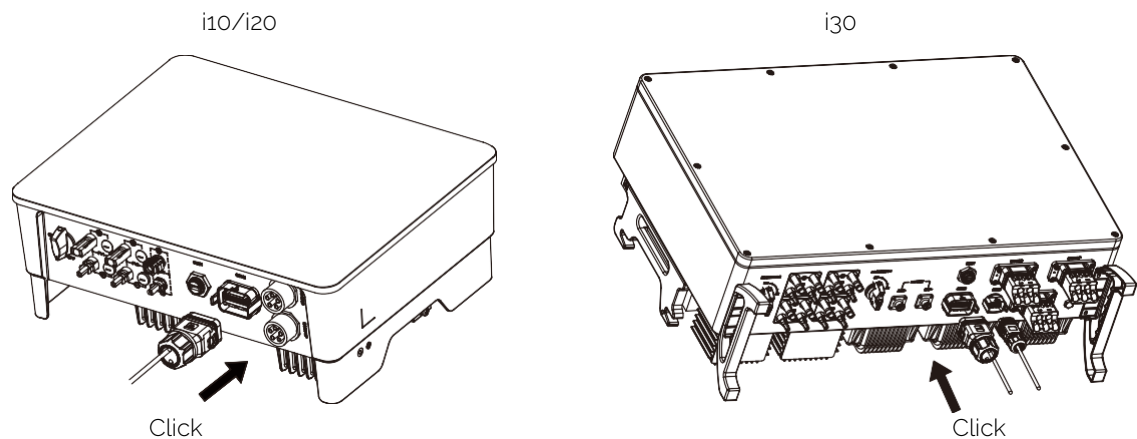

PV CONNECTION



High voltage may be present in the inverter! Before working on the electrical system, make sure that all cables are disconnected from the power supply. Only switch on the DC switch and the AC circuit breaker once the electrical connection work has been completed.

It is best to use PV modules of the same model and specifications in each string.

The maximum PV input voltage is 850 V when using the battery storage system; otherwise, the inverter remains in standby mode.



Please observe the maximum permissible input currents and voltages for the PV connection. These can be found in the data sheet for the inverter. This determines the maximum power of the connected PV system.

SYSTEM CONFIGURATION OF DEVICES WITH EXTERNAL DC SWITCH

Local standards or regulations may require PV systems to be equipped with an external DC switch on the DC side. The DC switch must be capable of safely disconnecting the open-circuit voltage of the PV array plus a safety margin of 20%. If necessary, install a DC switch on each PV string to isolate the DC side of the inverter.

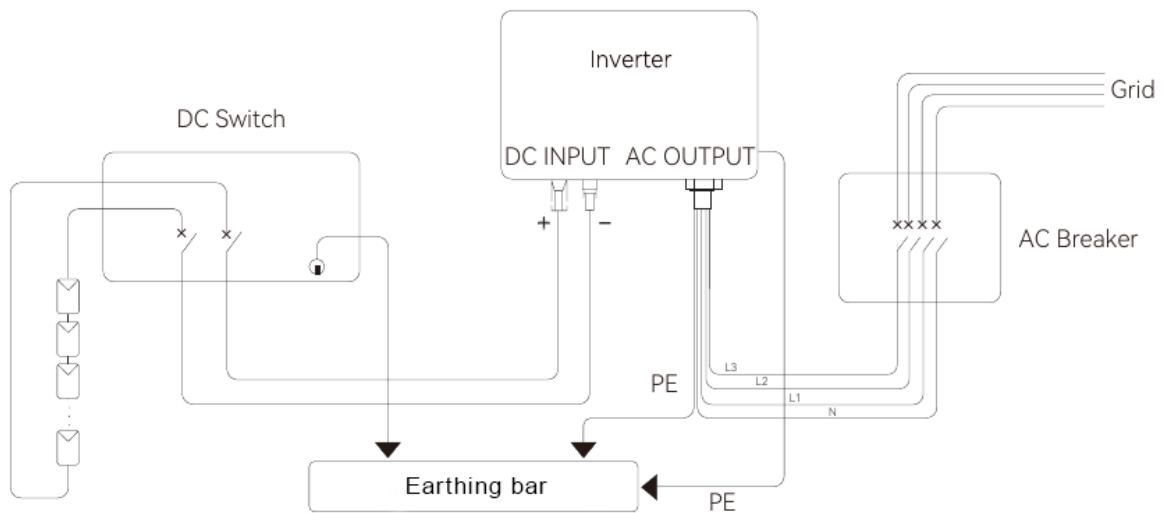

SELECTING A SUITABLE PV CABLE

Cable requirements		Length of stripped cable insulation
Outer diameter 5.9-8.8 mm	Conductor Cross section 4 mm ²	7 mm

ASSEMBLING THE PV CONNECTOR



Before assembling the DC plug connector, make sure that the cable polarity is correct. Please distinguish between the U-profile pin (PV connection) and the O-profile pin (blue - battery connection). We recommend using *Phoenix CRIMPFOX-RC 10* for crimping U-profile pins.

Insulate the DC cable to a length of 7 mm.



Disassemble the connectors.

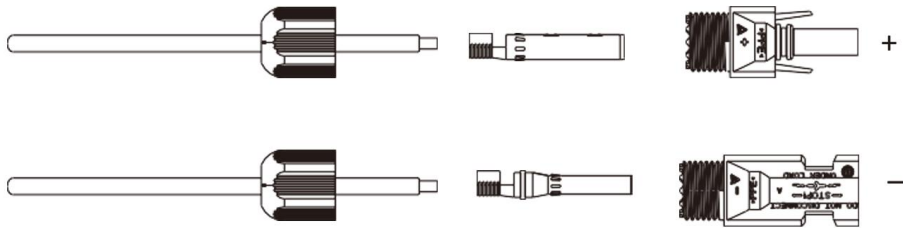

Insert the DC cable through the nut of the DC connector into the metal terminal and press the terminal with professional crimping pliers (pull the cable with moderate force to check the connection between the terminal and the cable).

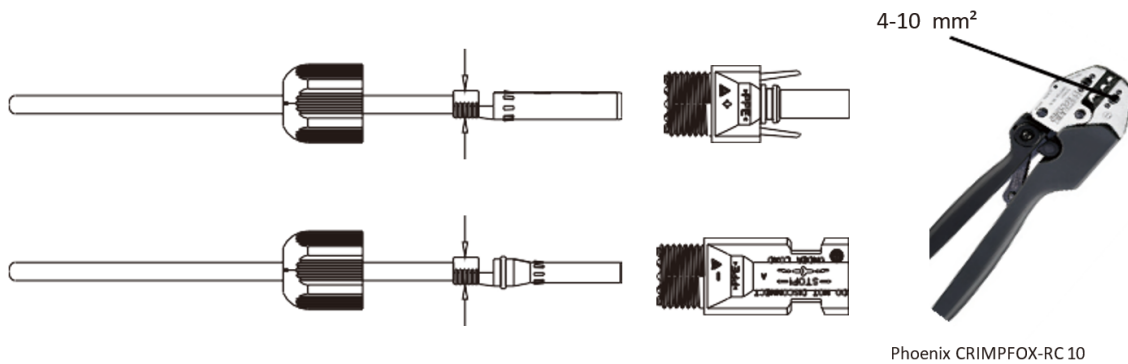

Plug the positive and negative cables into the corresponding positive and negative connectors and pull on the DC cable to check that the connection between the terminal and connector is secure. Screw the nut onto the end with a flat wrench to ensure that the terminal is tightly sealed.

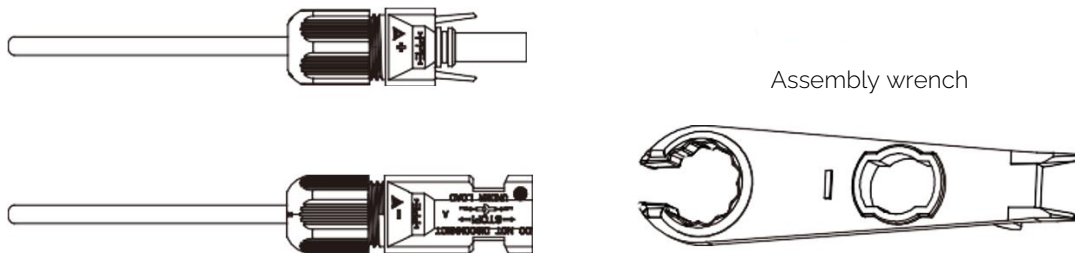

ATTACHING THE PV CONNECTOR

Turn the DC switch to the "OFF" position.

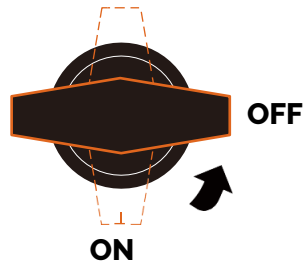

Check the cable connection of the PV string for correct polarity and ensure that the open-circuit voltage does not exceed the input limit value of the inverter (1000 V) under any circumstances. The maximum PV input voltage is 850 V when using a storage unit; otherwise, the inverter remains in standby mode. Without a storage unit, it is 950 V.

Plug the positive and negative connectors into the corresponding DC input terminals on the inverter. When the terminals are connected correctly, you should hear a clicking sound.

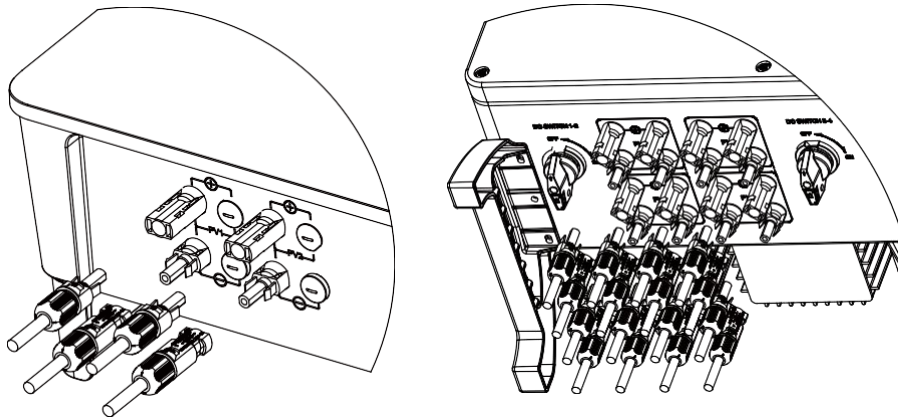

Close the unused PV terminals with the terminal caps.

II. BATTERIES

A. S1 BASE

All necessary electrical connections are established by attaching the S1 BAT 2.5 to the S1 BASE. No further cable connections are required.

B. S1 BAT 2.5

Stacking the S1 BAT 2.5 modules on top of each other establishes all necessary electrical connections. No further cable connections between the battery modules are required.

C. S1 BMS

All necessary electrical connections are made by stacking the S1 BMS on top of the top S1 BAT 2.5. No further cable connections need to be made between the BMS and the battery modules. However, depending on the number of battery towers or BMS used, further connections must be made as described in the following sections.

USE OF ONE BATTERY TOWER (7.7-25.6 KWH)

Before you start connecting the cables, please observe the following requirements to ensure personal safety:

1. Switch off the breaker switch on the mains side.
2. Switch off the battery breaker switch.
3. Switch the DC switch of the inverter to the "OFF" position. It is located on the underside of the inverter.

To connect the power cables, connect the "P+" and "P-" terminals to the battery terminals on the bottom of the inverter. This is the same for all i-Series inverters. Press the plugs into the terminals until you hear a "click" sound.

USE THE PRE-MADE BATTERY CABLES FOR THE CONNECTION!

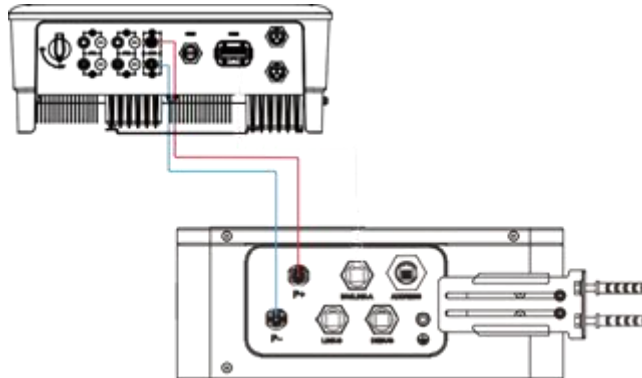

Before connecting to the inverter, make sure that the cable polarity is correct. Use a multimeter to measure the voltage of the battery pack and ensure that the voltage is within the limits of the inverter.

COMMUNICATION CABLE CONNECTION

When you are using a single battery tower, plug the BMS communication cable that is already connected to the COM2 connector into the corresponding connection on the BMS. Note that the COM2 connector is pre-wired and supplied with the EMX. See also section EMX.

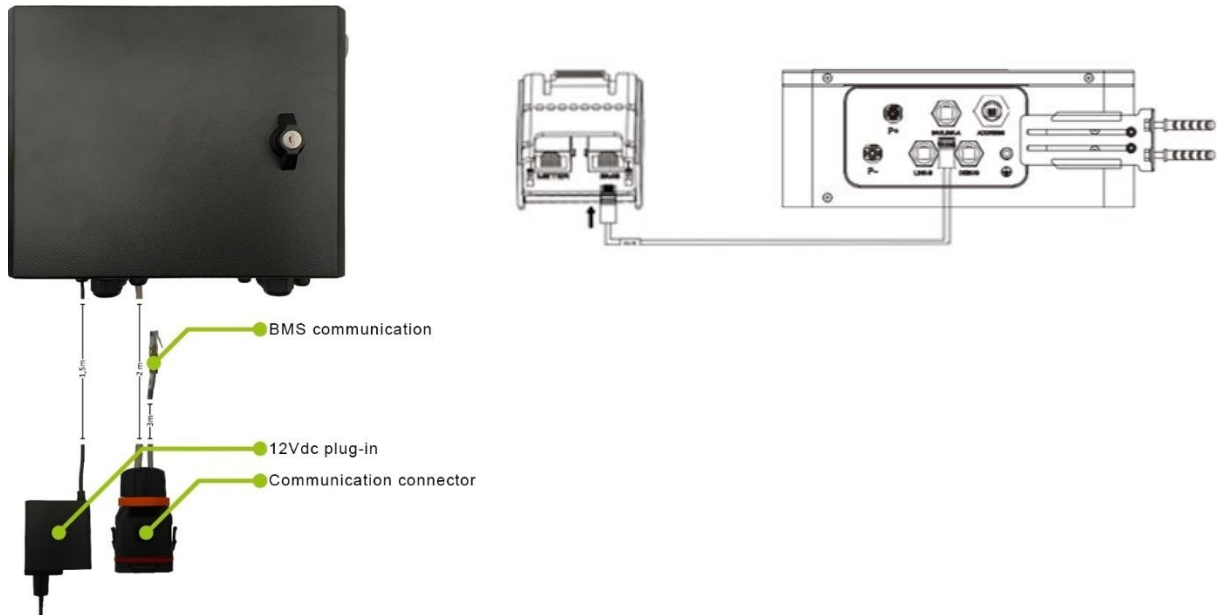

GROUNDING

Connect a suitable grounding cable to the side of the BMS. Always adhere to the local requirements and regulations!

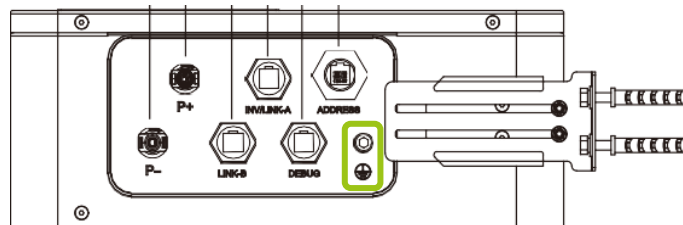

D. S1 MULTI

When installing multiple battery towers (28.2-76.8 kWh), the S1 MULTI must be used to connect the individual towers in parallel.

Before you start connecting the cables, please observe the following requirements to ensure personal safety:

1. Switch off the breaker switch on the mains side.
2. Switch off the battery breaker switch.
3. Switch the DC switch of the inverter to the "OFF" position. It is located on the underside of the inverter.

To connect the power cables, connect the "P+" and "P-" terminals of the BMS to the battery terminals on the underside of the S1 MULTI. Press the plugs into the terminals until you hear a "click" sound.

USE THE PRE-ASSEMBLED BATTERY CABLES FOR THE CONNECTION!

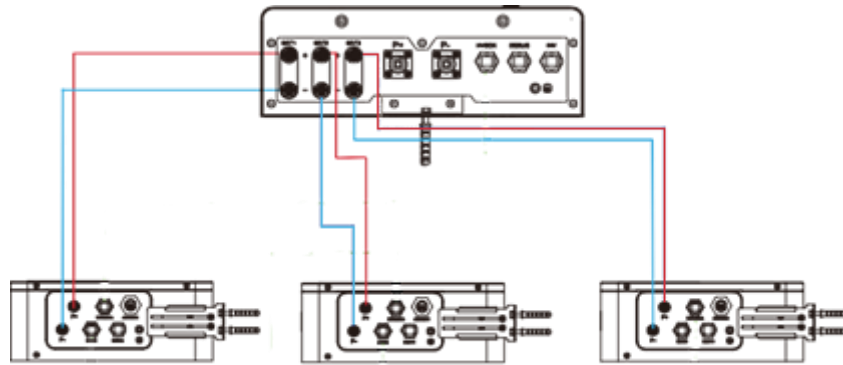

Then connect the "P+" and "P-" power connections of the MULTI to the battery connections on the underside of the inverters.

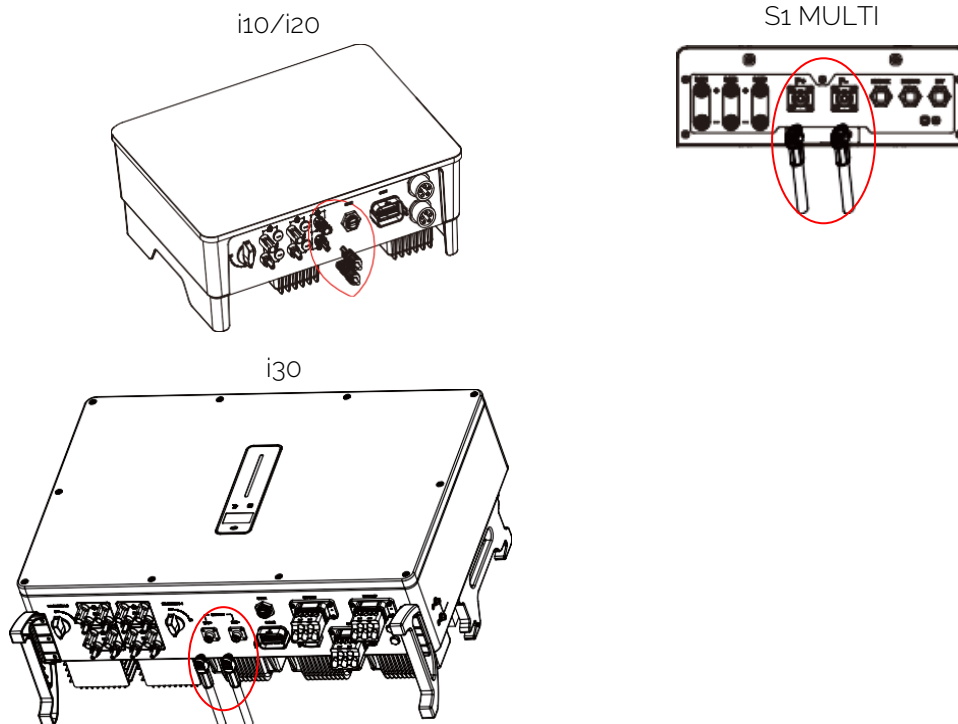

Use the pre-assembled battery cables for connection!



Before connecting to the inverter, ensure that the cable polarity is correct. Use a multimeter to measure the voltage of the battery pack and ensure that the voltage is within the limits of the inverter.

GROUNDING

Grounding of the MULTI is provided via the power supply cable.

COMMUNICATION CABLE CONNECTION

If you are using multiple battery towers, connect the various BMSs to the MULTI as shown here:

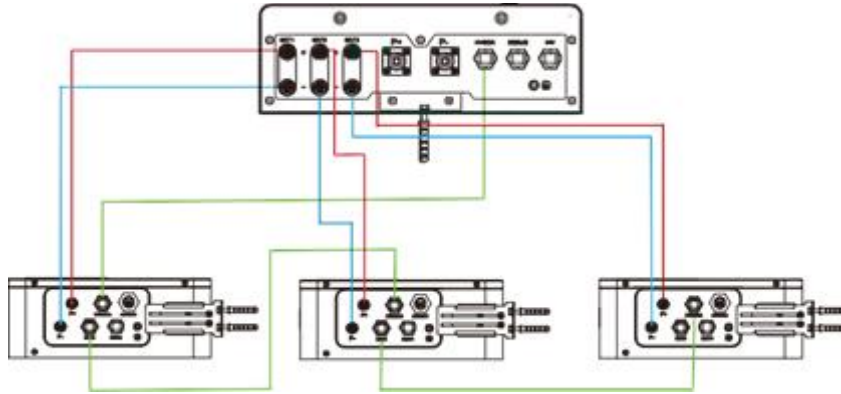

Then connect the MULTI to the communication cable that is already connected to the COM2 connector on the EMX. See also section EMX

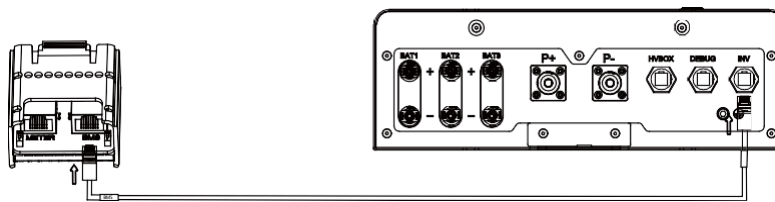

If a MULTI is required, the addresses of the connected battery towers must be changed so that the MULTI can recognize them. Set the address 0 for the first battery tower.

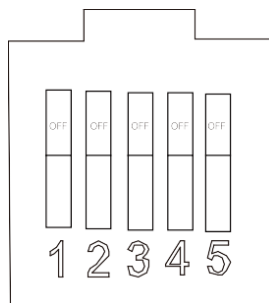

Address	DIP1	DIP2
0	OFF	OFF

Set address 1 for the second battery tower.

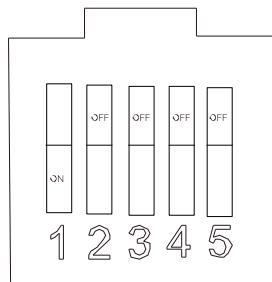

Address	DIP1	DIP2
1	ON	OFF



Set address 2 for the third battery tower.

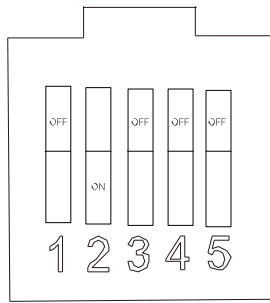

Address	DIP1	DIP2
2	OFF	ON

Switch DIP5 of the battery tower connected to the MULTI to the "ON" position. For example, if the third battery tower is connected to the MULTI, the address is:

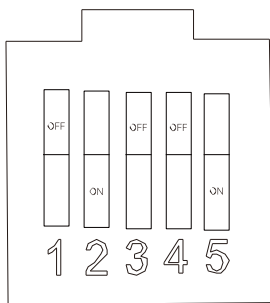

Address	DIP1	DIP2	DIP3	DIP4	DIP5
2	OFF	ON	OFF	OFF	ON

III. EMX

To make the EMX ready for operation, the following connections must be installed:

Communication: Plug the EMX communication connector into the appropriate interface on the inverter (port 'COM 2').



BMS communication: Plug the open end of the BMS communication cable into the 'INV/LINK-A' slot on the BMS. If there are several BMS units connected to the MULTI, plug the cable into the 'INV' connection on the MULTI.

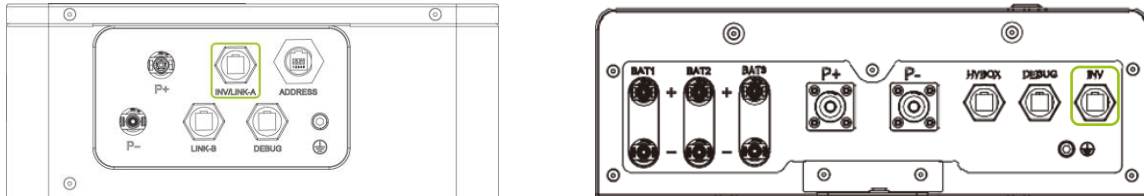

Energy Meter: The supplied cable, which is marked "Meter" on both sides, is used here to connect the energy meter to the corresponding interface of the EMX.

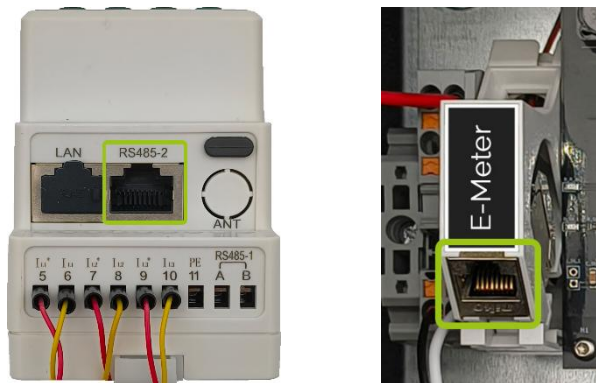

Inputs: The system has 4 inputs that can be configured via the batterX portal. The inputs are activated by a potential-free connection/contact.

! *No external voltages may be connected to these contacts.*

Outputs: The EMX has 4 potential-free output contacts. These contacts are relay contacts, which can also be freely programmed via the batterX portal. These contacts may be operated with a voltage of $< 50 V_{DC}$ and a current of 1 A. Outputs 1-3 are configured as normally open (NO) contacts and output 4 as a normally closed (NC) contact by default. This configuration can be changed at any time by repositioning the jumper located above the respective relay.

- NO (normally open) → Relay contact is configured as a normally open contact
- NC (normally closed) → Relay contact is configured as normally closed

There is also a status LED to the left of each relay, which lights up when the relay is activated.

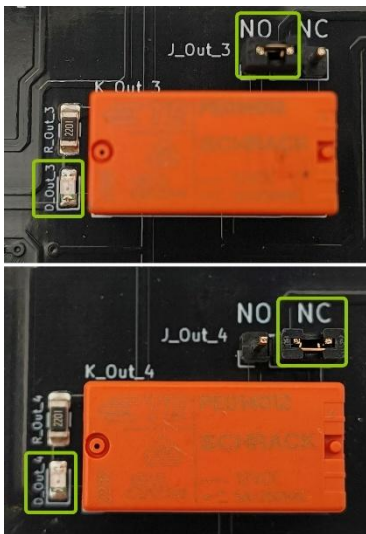

TERMINAL ASSIGNMENT FOR INPUTS AND OUTPUTS:

The terminal assignment for the individual contacts is as follows

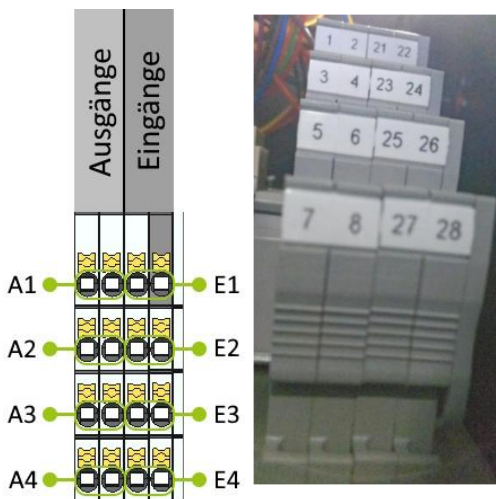

- Permissible cross-sections of the individual terminals are:
- 0.14-4 mm² rigid
 - 0.14-4 mm² flexible
 - 0.14-2.5 mm² with ferrule (with or without plastic insulation)

Wire end ferrules and rigid cables can be easily inserted into the terminal. When connecting flexible cables and to disconnect all variants, the orange release must be pressed in first.

IV. E-METER

The electricity meter (= E-Meter) is installed at the feed-in point of the electrical installation, usually directly after the energy supplier's meter. The current transformer is usually installed on the L-conductor between the house consumers and the power grid. The current transformer cable has a fixed length of 2 m and cannot be extended. The communication connection must be established between the E-Meter and the EMX. If an external on-grid inverter is to be integrated into the portal, it can be recorded using an additional energy meter. To do this, it must be assigned the correct address.

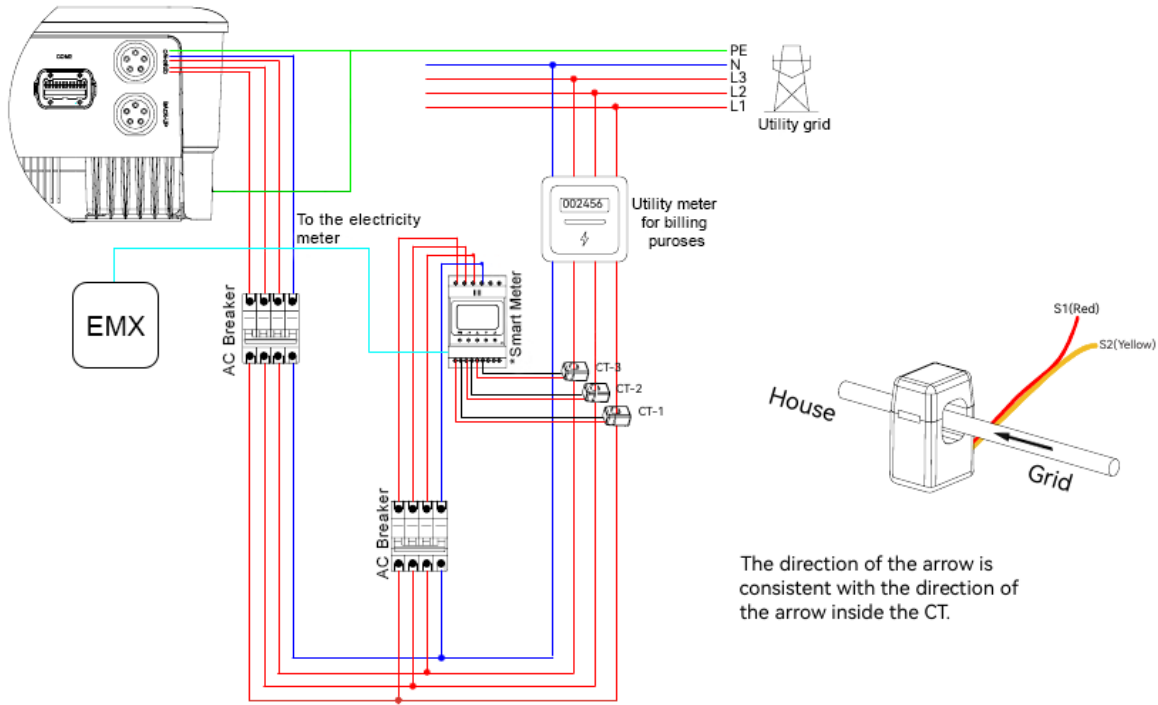

The direction of the arrow is consistent with the direction of the arrow inside the CT.

! The current transformer must be installed strictly in accordance with the instructions in the user manual, otherwise the inverter may not function properly. The current transformer must correspond to the connection in the electricity meter, and the connection between the current transformer and the electricity meter must be reliable, otherwise measuring accuracy of the current transformer may be impaired.

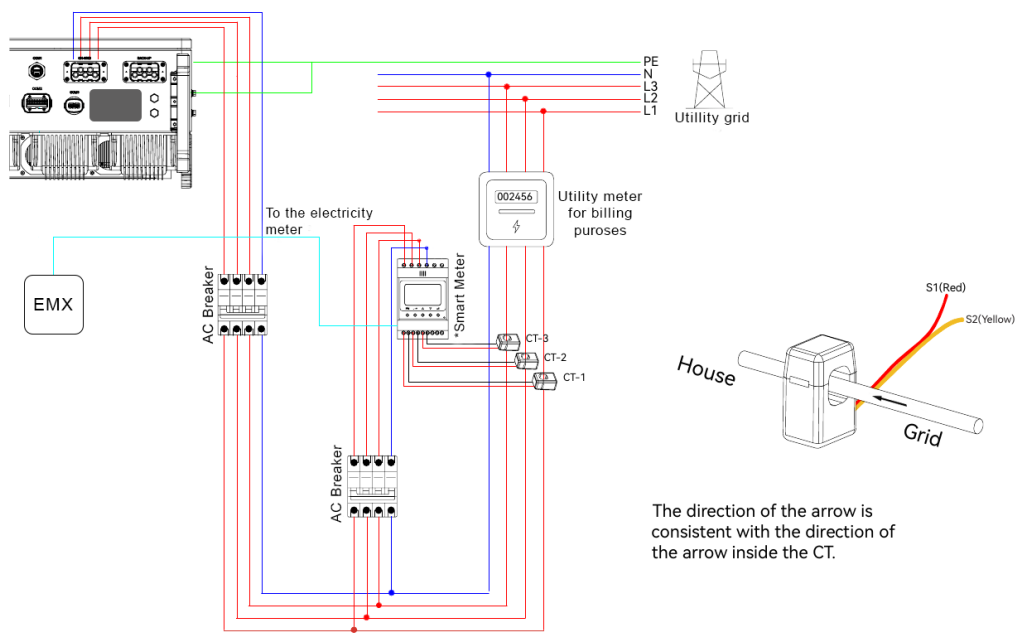

The direction of the arrow is consistent with the direction of the arrow inside the CT.



The definition of the electricity meter connections is listed in the table below:

No.	Definition	Function
1	U_{L1}	L1/L2/L3/N are connected to the mains to determine the mains voltage.
2	U_{L2}	
3	U_{L3}	
4	U_N	
5	I_{L1}	Connection of current transformers for measuring current and flow direction.
6	I_{L1}	
7	I_{L2}^*	
8	I_{L2}	
9	I_{L3}^*	
10	I_{L3}	
11	PE	Grounding connection
A	RS485-1	Use only with multiple E-meters
B	RS485-1	
RS485-2	RS485-2	Communication with EMX
ANT	Reserve	
LAN	Reserve	
Type C	Type-C	Specified debug interface. For use by experts only!

The supplied cable, marked "Meter" on both sides, is used to connect the Energy Meter to the corresponding interface of the EMX.



6. COMMISSIONING

CHECKS BEFORE COMMISSIONING

Before commissioning the inverter, check the following points:

- All devices are installed securely.
- The DC switch and AC circuit breaker are in the 'OFF' position.
- The grounding cable, AC cable, DC cable, and communication cable are properly and securely connected.
- The free terminals are tightly closed and sealed off.
- There are no foreign objects, such as tools, on top of the device or in the connection box (if present).
- The AC circuit breaker has been selected in accordance with the requirements of this manual and local standards and regulations.
- All warning signs and labels are intact and readable.

STARTUP PROCEDURE

If all of the above points meet the requirements, proceed as follows to start up the system for the first time.

- Switch on the AC circuit breaker in the inverter supply line.
Please note that it may take a few seconds for the inverter display to light up.
- Plug the EMX power supply unit into a socket that is supplied via the inverter's backup output.
- When using the MULTI: Plug the MULTI power supply plug into a socket that is supplied via the inverter's backup output.
- When using the MULTI: Switch the breaker switch (2) on the front of the MULTI to the ON position.

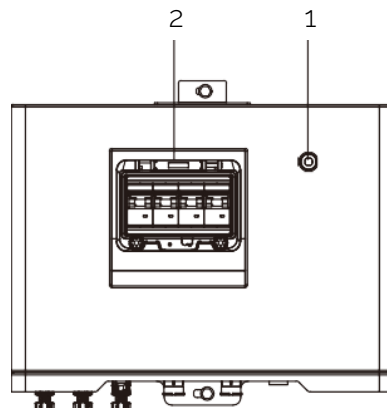

- Switch on the breaker switch on the left side of the BMS module. (When using the MULTI: Repeat this step for all BMS modules).

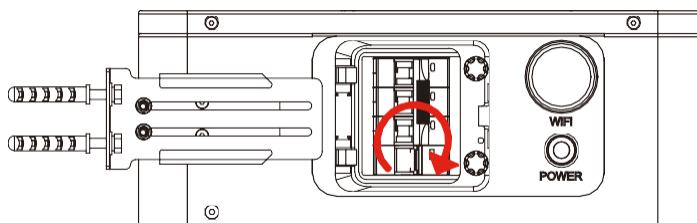

- Press and hold the "POWER" button on the BMS for 3 seconds until the display flashes green. The battery will now perform a self-test, which may take a few seconds. (When using the MULTI: Repeat this step for all BMS modules).

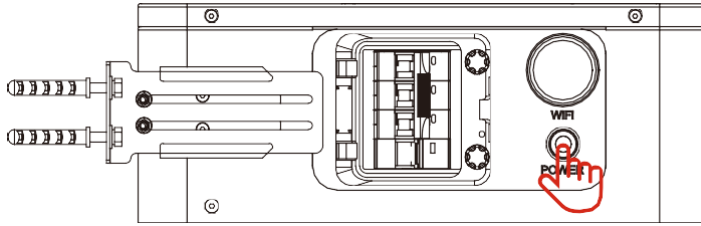

- When using the MULTI: Press the "ON" button on the front (1).
- Wait until the light on the "POWER" button lights up green (this may take up to 5 minutes).
- The inverter will now perform a grid test, which takes approx. 60 seconds.
- Switch on the DC switch(es) on the underside of the inverter.

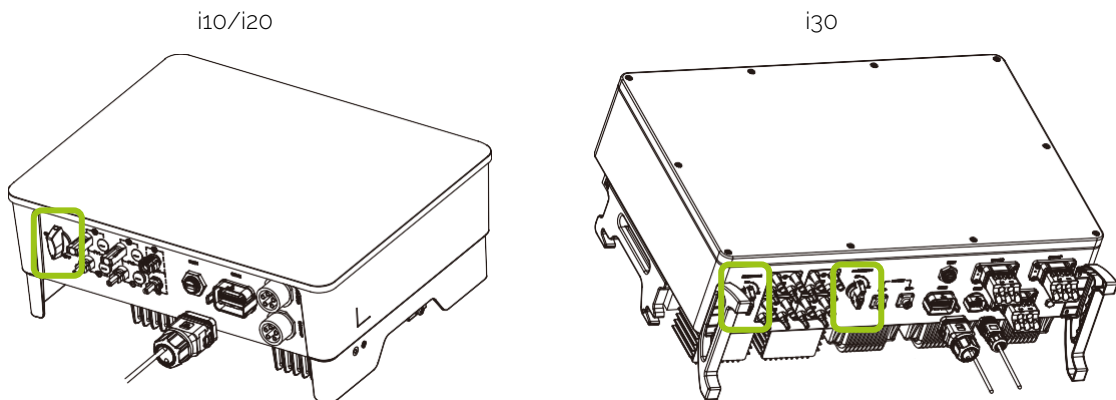

- The inverter will operate correctly after switching on the DC and AC circuit breakers, provided that the weather and grid conditions meet the requirements.
- Observe the LED display to ensure that the inverter is functioning properly.
- As soon as the EMX is supplied with power via the inverter output, it switches on and the light on the right side of the housing illuminates.

SWITCHING OFF THE SYSTEM

- Shut down the batterX monitoring via the portal.
- Open the circuit breakers on the mains and load side.
- Open the circuit breakers on all BMS modules and MULTI (if present).
- Switch the DC switch(es) on the underside of the inverter to the "OFF" position.
- Wait until the inverter display goes blank.
- At this point, the inverter capacitor is still charged. Therefore, wait 10 minutes before proceeding to ensure that the inverter is completely de-energized.

7. INSTALLATION ROUTINE

batterX recommends performing the installation routine with a laptop or tablet.

Open the browser¹ on a laptop/tablet and enter <http://batterX> or batterx/ in the address bar. If the liveX cannot be accessed in this way, it can be found using "liveX IP finder." To do this, simply enter <https://batterx.app/ipfinder.php> in the address bar² and enter the serial number of the EMX there.

batterX liveX IP finder:

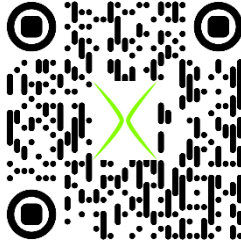

Language: Select your preferred language.

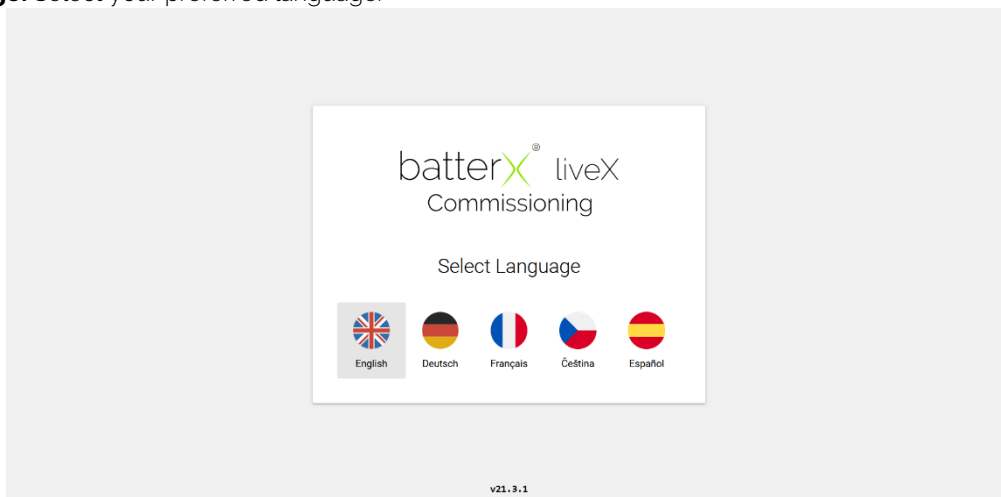

Software update: The system will check for software updates. If a new version is available, it will be downloaded and installed. This may take a few minutes.

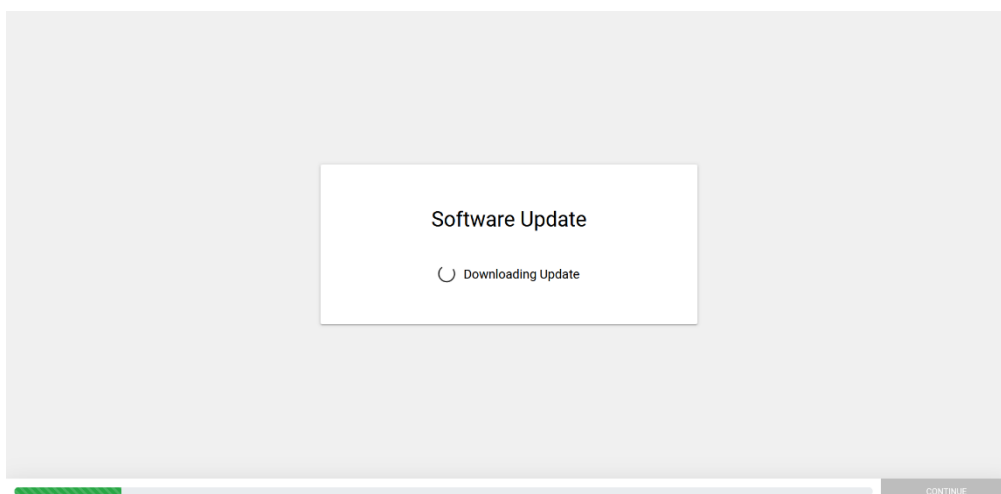

¹ Internet Explorer is not supported

² The PC/laptop/tablet must be in the same network as the batterX system.

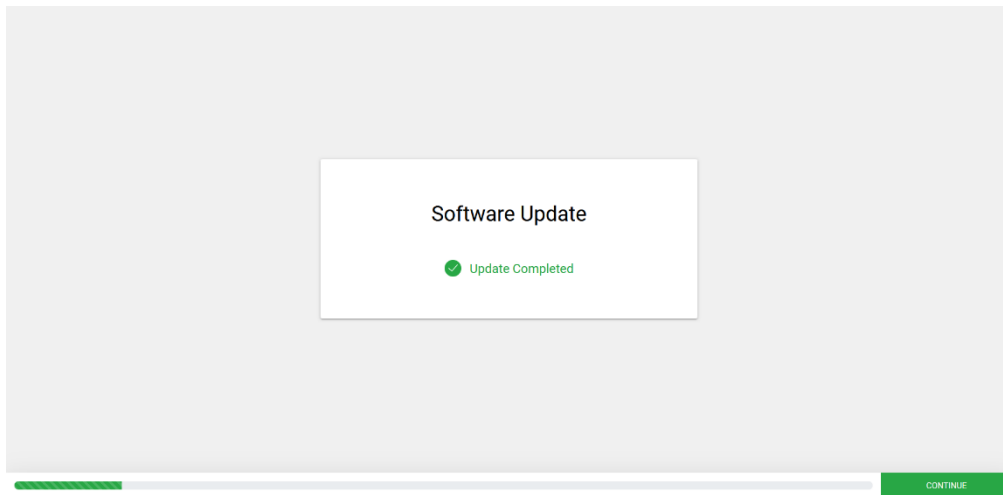

Installer login: The installer must log in with their own account. This automatically assigns this system to that account³. There can only be one account per company.

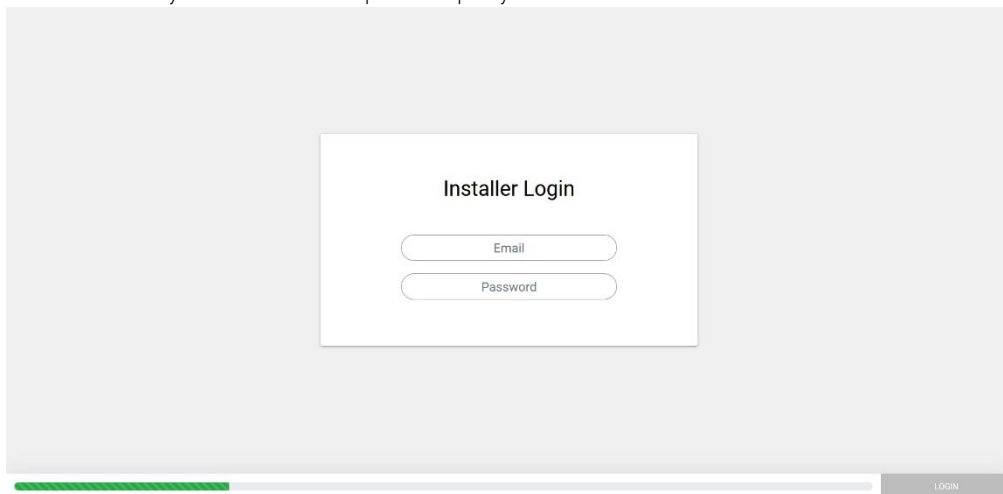

Customer information: Enter customer information, installation address, and installer⁴. If the installation address is the customer's address, please check "Same as customer address." The "Installer on site" field is required to assign an installer from the company to the system, as the entire company shares an installation account.

³ This account is created by batterX after certification training.

⁴ This field allows you to distinguish between different installers within a company, as they use the same company account.

Customer Information

Mr. First Name Last Name

Company E-Mail Telephone

Luxembourg City Zip Code

Address

Installer on site (Name)

Installation Address

Same as customer address

Device type: The inverter type, serial number, and standard norm are automatically detected by liveX. If the set standard norm does not meet your requirements, it can also be changed here.

batterX i-Series

S/N: B1123A0104430862

VDE4105

VDE4105*

System information: Inverter, PV, BMS, and battery information must be entered here.

batterX Home

New System Existing System

IE01250004

Serial number of the inverter: B1123A0104430862

Serial number of the EMX: 2501IE0003

INSTALLER MEMO

PV-System

Size of the PV-System: 10000 Watt Peak (Wp)

How much percent of solar power can be fed to grid in terms of peak power? %

Dynamic feed-in control of the entire PV system

PV-Installation Info

Paneltyp: ...

MPPT 1 String 1: ... String 2: ...

External Solar Meter Connected

USER ENERGY METERS

Batteries

LiFePO No Battery

S/N of each BMS module: B182500200101822

S/N of each battery module: B182501202C01812 B182501208A01812 B18250120C201812 B18250120F01812

SteuVE nach §14a EnWG

- **System serial number:** This is automatically generated at the end of the installation routine.
- **Inverter serial number:** This serial number is located on the side of the inverter but is automatically read by the system.
- **EMX serial number:** The serial number of the EMX is automatically read by the system.



- **Installer memo:** Optional information for the installer.
- **Size of the PV system:** Total power of the installed PV system (in watts).
- **Feed-in limitation:** A factor that specifies how much of the installed PV power may be fed into the grid.
- **Dynamic feed-in control of the entire PV system⁵:** This function allows the system to control the entire PV system. To do this, the inverter can reduce PV production to 0% instead of 70%. This requires that at least the generator power to be limited is connected.

Total PV	30 kW
Control	70
PV inverter	≥ 9 kW (30%)
PV external	≤ 21 kW (70%)

- **PV installation info:** Optional information regarding the PV system.
- **External solar system meter connected:** If an external grid-connected inverter with an additional energy meter is to be recorded, this checkbox must be selected. In addition, a second energy meter is queried and checked during the system test.
- **Independent consumption meters:** The independent consumption meters allow specific loads (and generators) to be recorded and displayed separately in the portal. It is important to note that this data is only displayed in the portal and has no influence on the energy flow calculations. Up to 4 consumption meters can be installed per system, each with a fixed Modbus address, which must be set accordingly. During commissioning, you should specify which of these meters is active. It is also recommended to give the meters appropriate names.

User Energy Meters

User Meter 1 (Modbus ID 101)

Connected

Label

User Meter 2 (Modbus ID 102)

Connected

Label

User Meter 3 (Modbus ID 103)

Connected

Label

User Meter 4 (Modbus ID 104)

Connected

Label

The data from the user meters is displayed in the dashboard, with the history shown in the extended window of the history menu.

- **Batteries:** Please specify whether LiFePo batteries are installed or whether the inverter is operated without batteries.
- **S/N of the BMS modules:** Specify the serial number of the BMS. If there are several BMSs, the serial number of the MULTI must also be entered here.
- **S/N of the individual battery modules:** The serial numbers of each individual module must be entered.

⁵ This option is only relevant if external network-connected generators are present in the system (e.g., PV system).

Setting the reactive power behavior⁶ : The mode specified by the energy supplier must be set. Some modes require additional parameters.

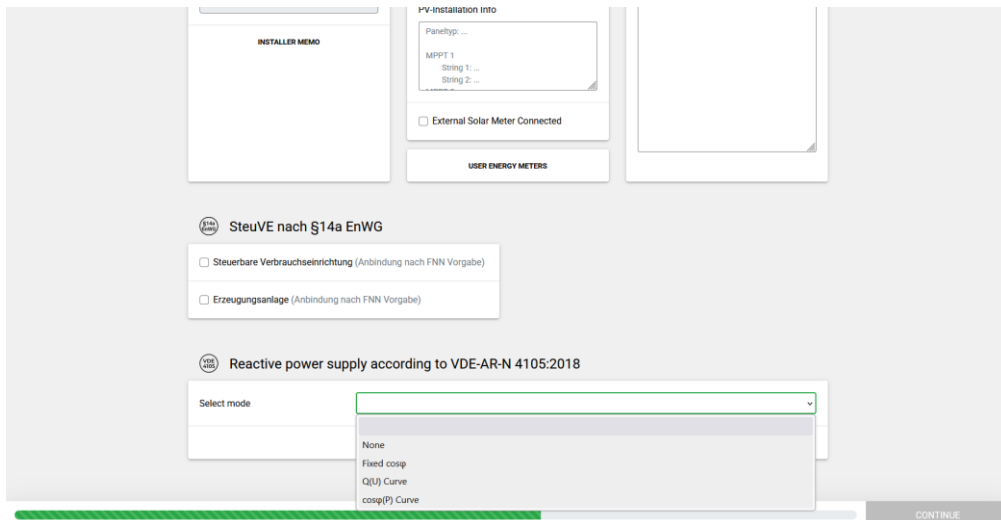

- **Mode: "None"**

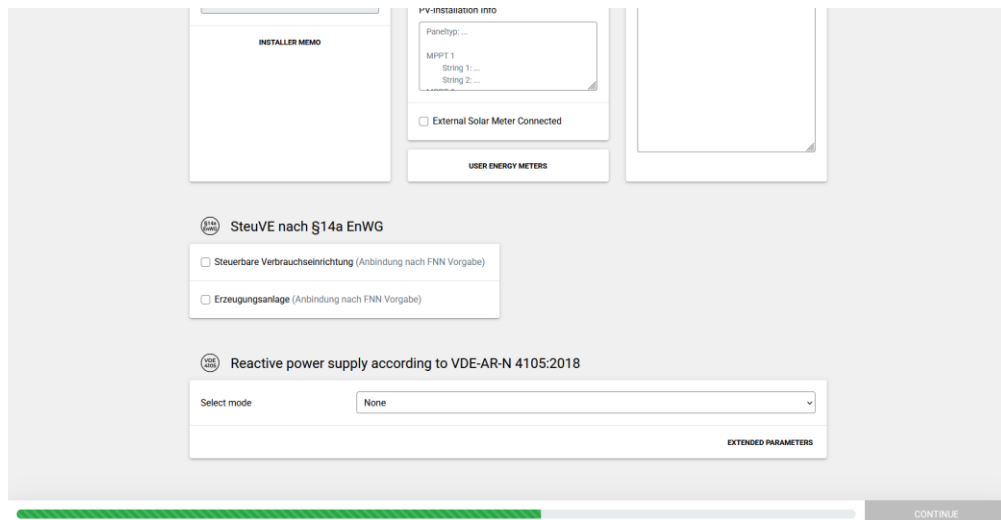

- **Mode "Fixed cosφ"**

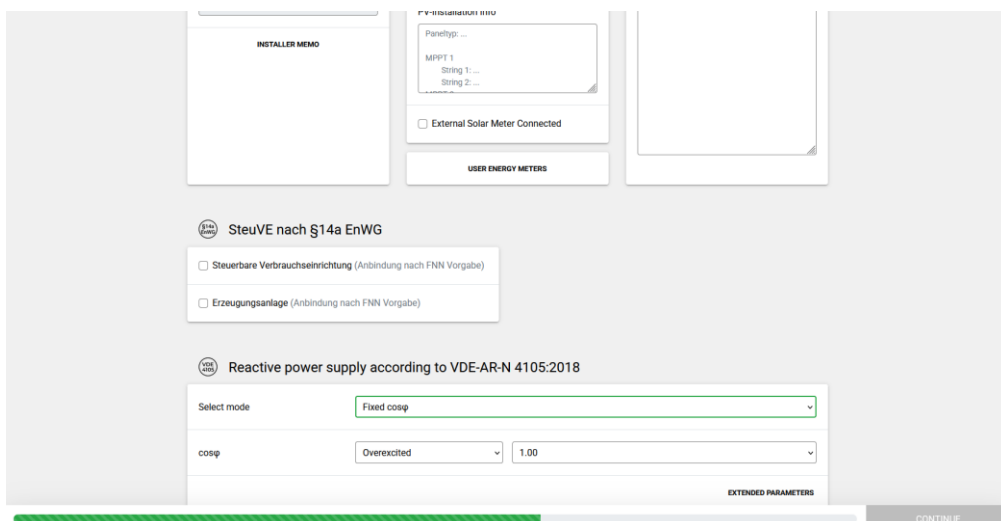

⁶ Only available for the "VDE4105", "TOR" and "Estonia" standards.

- Mode "Q(U) characteristic curve"

INSTALLER MEMO

External Solar Meter Connected

USER ENERGY METERS

Reactive power supply according to VDE-AR-N 4105:2018

Select mode: Q(U) Curve

U1: %

U2: %

U3: %

U4: %

cosφ:

EXTENDED PARAMETERS

- Mode "cosφ(P) characteristic curve"

INSTALLER MEMO

External Solar Meter Connected

USER ENERGY METERS

Reactive power supply according to VDE-AR-N 4105:2018

Select mode: cosφ(P) Curve

EXTENDED PARAMETERS

- Mode "Fixed reactive power (Qfix)"⁷

INSTALLER MEMO

External Solar Meter Connected

USER ENERGY METERS

Reactive power supply according to TOR

Select mode: Fixed Reactive Power (Qfix)

Qfix: VAR

EXTENDED PARAMETERS

⁷ Only available for the 'TOR' standard.

- **Advanced settings**

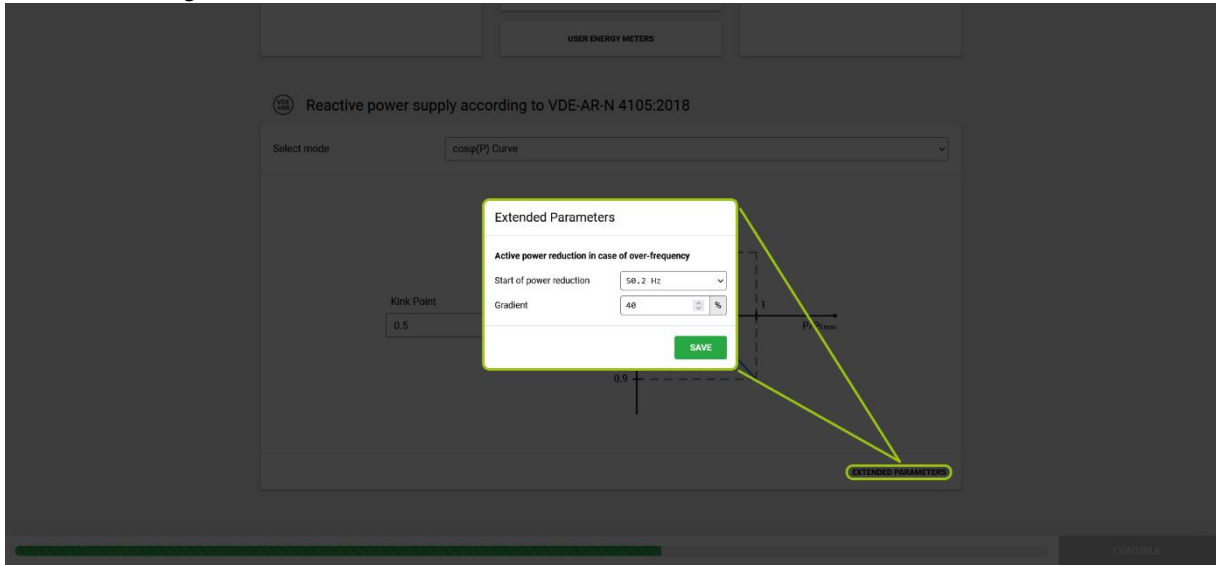

- **Advanced settings**⁸

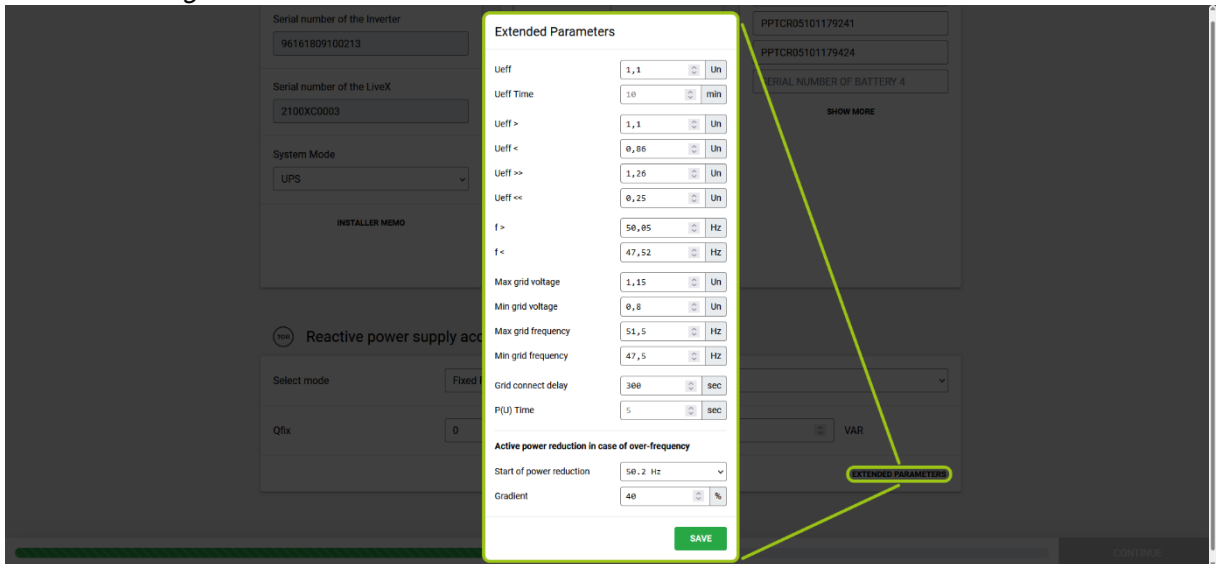

The parameters are then sent to the inverter before proceeding to the next step.

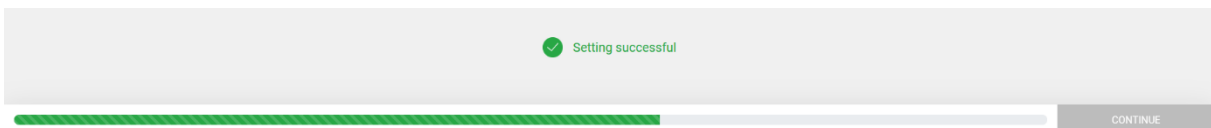
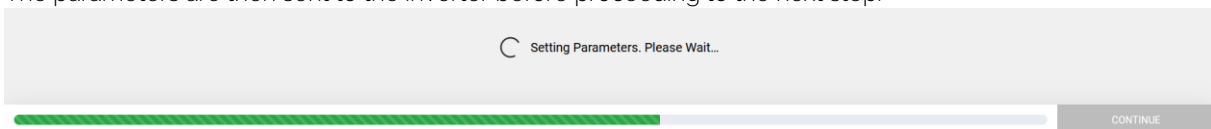

⁸ Only available for the 'TOR' standard.

System test: A system test is performed, which checks the individual functions of the system in sequence so that the installation can then be completed.

- **Energy meter:** Checks whether communication with the energy meter has been established.

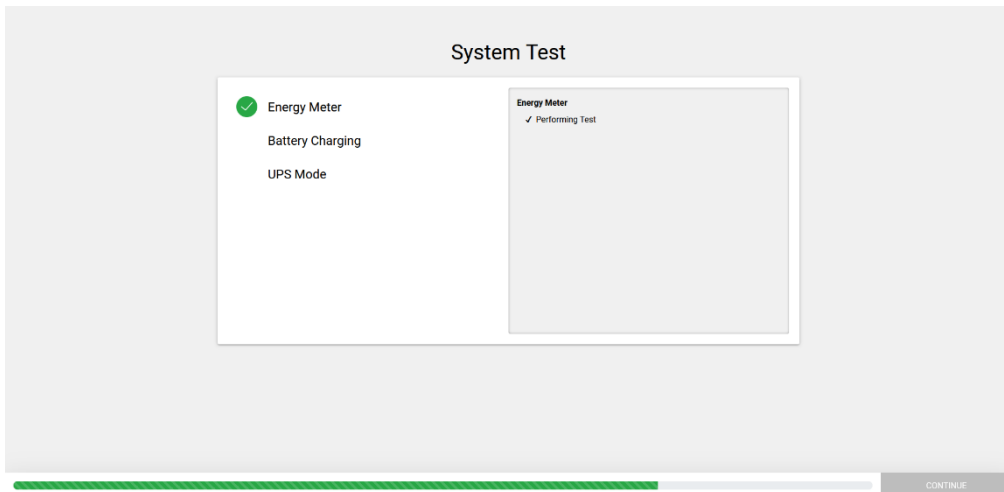
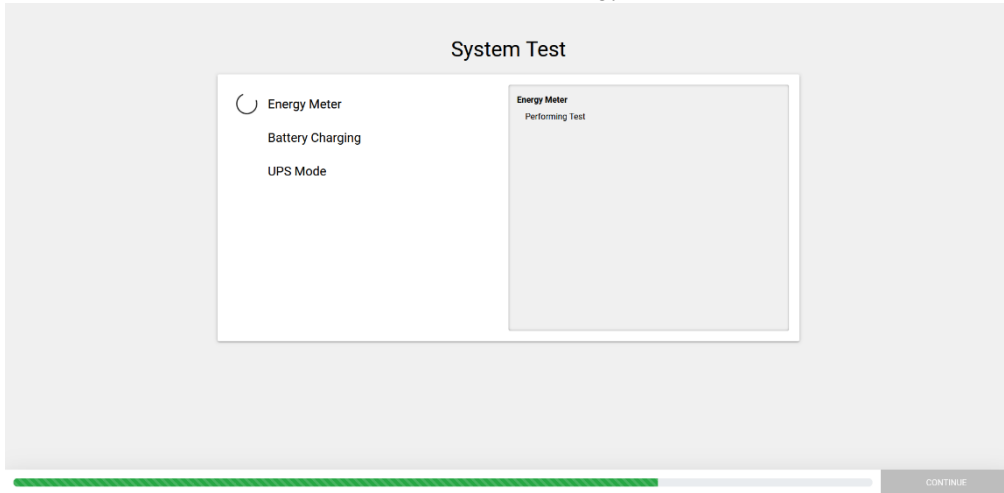

- Battery charge:** When testing the battery charge, the SoC (state of charge) is always checked first. If it is below 20%, the battery is charged to this level so that sufficient reserve capacity is available for the discharge process of the test. If the value is above 90%, the battery is discharged to this level so that reserve capacity is available for the test charging process.

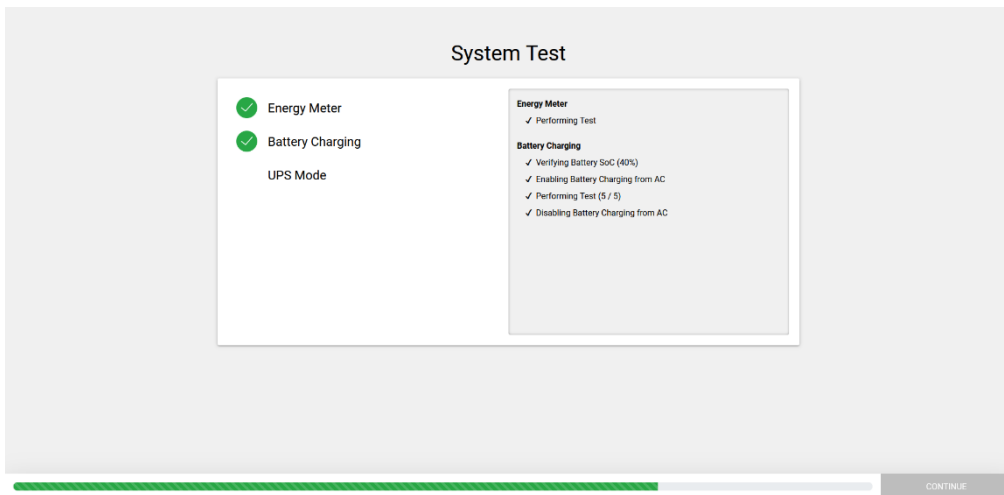
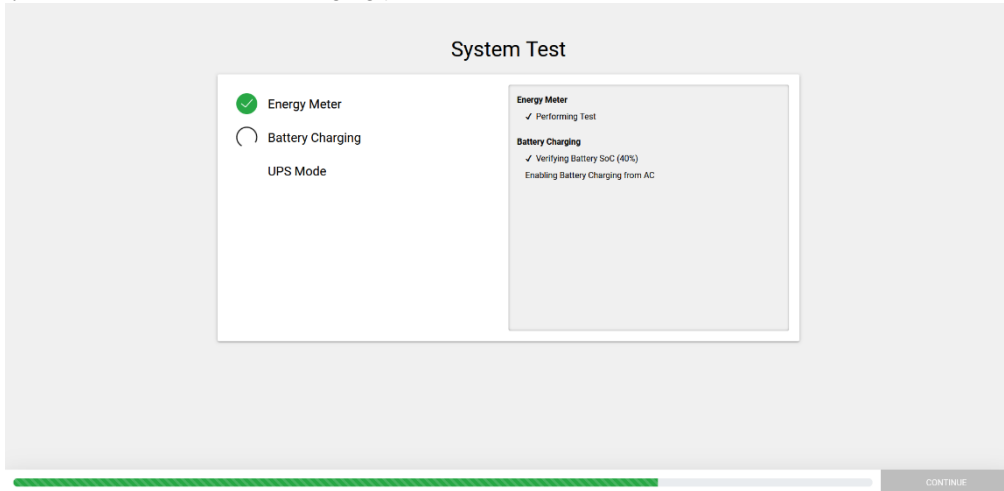

- UPS mode:** To perform a realistic test of the UPS mode, the power supply must first be disconnected and then reconnected. This should only be done when prompted by the installation routine.

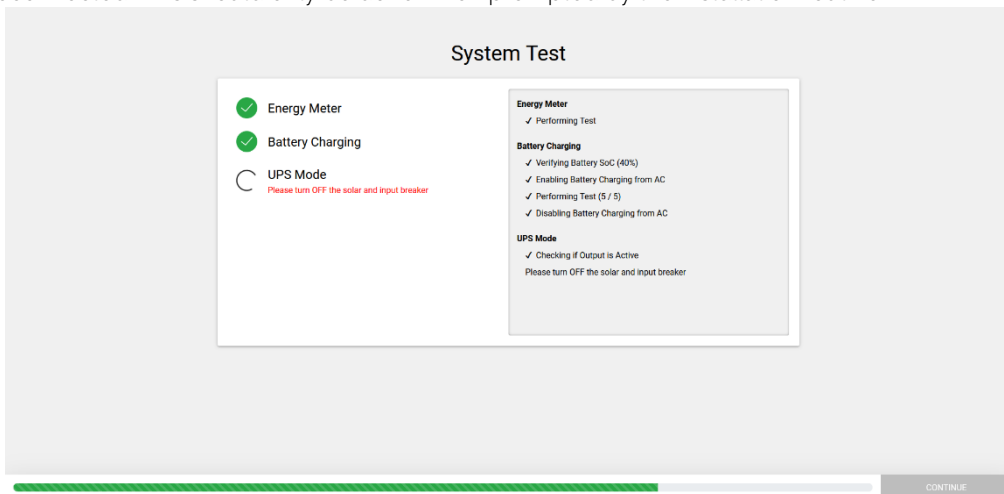

System Test

- ✓ Energy Meter
- ✓ Battery Charging
- UPS Mode

Energy Meter

- ✓ Performing Test

Battery Charging

- ✓ Verifying Battery SOC (40%)
- ✓ Enabling Battery Charging from AC
- ✓ Performing Test (5 / 5)
- ✓ Disabling Battery Charging from AC

UPS Mode

- ✓ Checking if Output is Active
- ✓ Please turn OFF the solar and input breaker
- Performing Test (1 / 5)

CONTINUE

System Test

- ✓ Energy Meter
- ✓ Battery Charging
- UPS Mode
Please turn ON the solar and input breaker

Energy Meter

- ✓ Performing Test

Battery Charging

- ✓ Verifying Battery SOC (40%)
- ✓ Enabling Battery Charging from AC
- ✓ Performing Test (5 / 5)
- ✓ Disabling Battery Charging from AC

UPS Mode

- ✓ Checking if Output is Active
- ✓ Please turn OFF the solar and input breaker
- ✓ Performing Test (5 / 5)

CONTINUE

System Test

- ✓ Energy Meter
- ✓ Battery Charging
- ✓ UPS Mode

Energy Meter

- ✓ Performing Test

Battery Charging

- ✓ Verifying Battery SOC (40%)
- ✓ Enabling Battery Charging from AC
- ✓ Performing Test (5 / 5)
- ✓ Disabling Battery Charging from AC

UPS Mode

- ✓ Checking if Output is Active
- ✓ Please turn OFF the solar and input breaker
- ✓ Performing Test (5 / 5)

CONTINUE

System warranty: The system warranty will then be displayed. Please read it carefully in full and confirm it by checking the box and clicking "Continue"

System warranty batterX Home&COM

This warranty applies to the Home&COM system.
 The warranty conditions are available in the user manual.

1. The warranty conditions apply to the Home&COM system. The warranty conditions are available in the user manual.

2. The warranty conditions apply to the Home&COM system. The warranty conditions are available in the user manual.

3. The warranty conditions apply to the Home&COM system. The warranty conditions are available in the user manual.

4. The warranty conditions apply to the Home&COM system. The warranty conditions are available in the user manual.

5. The warranty conditions apply to the Home&COM system. The warranty conditions are available in the user manual.

I confirm that I have read all [warranty conditions](#) as well as [privacy](#) and [cookie policies](#) and that I fully understand and accept them.

CONTINUE

Installation report: A summary of the data entered is then displayed. This must be confirmed again. In addition, you must agree to relieve the system of overloads if these occur regularly. This ensures the longevity of the device.

Installation Summary		 <small>POWERED BY VISION UPS</small>
Installation Date	2020-02-11	
Latest Maintenance	2021-05-17	
Installer		
Name	Mr. Mustermann	
Company	Vision UPS - Installer	
Email	email@visionups.com	
Telephone	00352 023456789	

I hereby confirm that the information above is true, complete and accurate.

It is hereby confirmed that the UPS load, including inrush and start-up currents, is correctly designed or, in the event of overloads with available mains, will be reduced to the permissible level within 1 month of the installation date, which is a prerequisite for the validity of the product warranty. It is pointed out that according to the warranty conditions, overloads during mains power failure will invalidate the warranty.

It is hereby confirmed that the operator of the system has been correctly briefed and provided with the relevant documentation.

FINISH INSTALLATION

Completion of the installation routine: Upon completion, an email with the login details is sent to the customer. It is also recommended to restart the EMX by pressing the blue button.

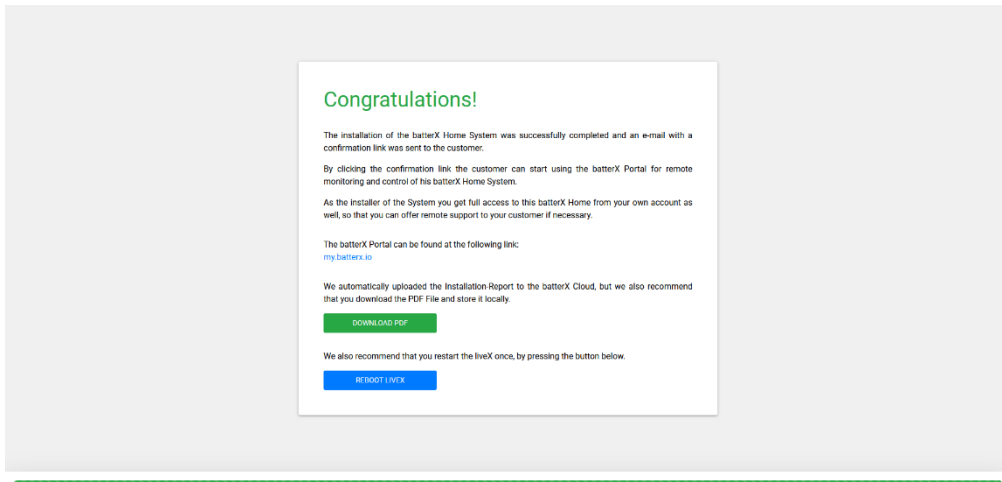

- **Customer email**

From: batterx <batterx.support@gmail.com>
 Sent: Thursday, February 26, 2023 8:26 AM
 To: Gertjan, hank <vision@visionups.com>
 Subject: [batterX] Please verify your account!

Congratulations!
 Your new batterX Home System has been successfully installed!
 To start using your system, please activate your account by clicking on the following link:
<https://batterx.app/account/verify.php?enginekey=915c607b1e883e4065d63d8ec921ef6c9bc78044195713e7211f9746f9>
 Your email address is: info@visionups.com
 Your password is: **batterx**
 We recommend that you change your password to a password of your choice.
 Please also note our [Privacy Policy](#).
 If you have any questions, please do not hesitate to contact us at info@batterx.de
 Yours sincerely
 batterX Service Team
 VISION UPS Systems S.r.l.
 Duquesnoystrasse 26, 1744 Dellen, Luxembourg
info@visionups.com
 batterx.de - batterx.com

- **Verification:** Before the customer account is verified, the customer must specify who will have access to their data. This information is required in the event of service issues so that the system can be remedied more quickly.

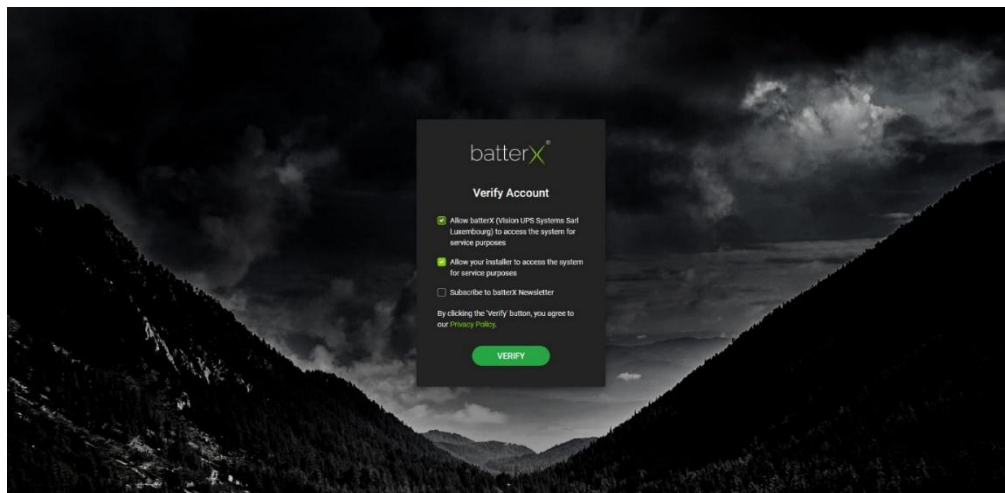

- **Login:** The customer can then log in via the app or <https://batterx.app>. The system should now also be visible to the installer in their account.

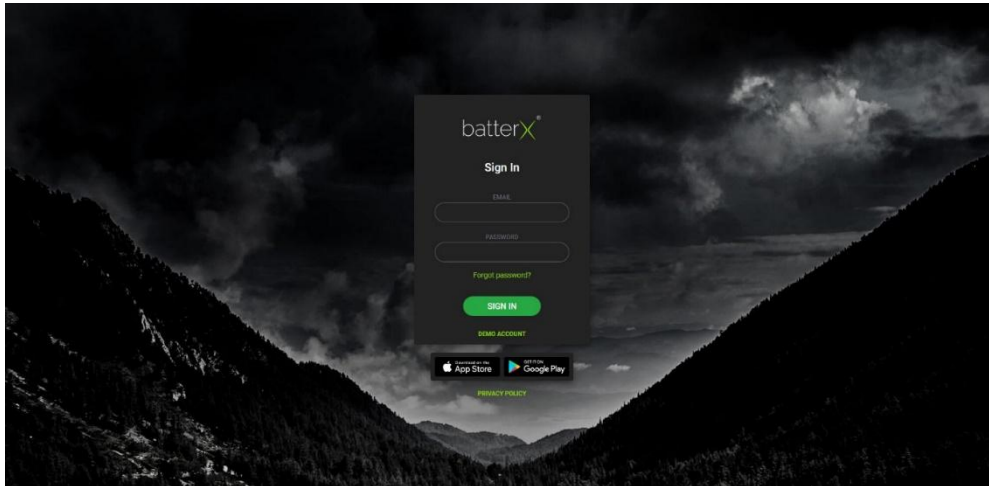

Congratulations, you have successfully completed the installation!

8. DYNAMIC ELECTRICITY PRICES

! *Note: For systems with microinverters, an individual case review and approval by batterX is required. Please contact batterX customer service for this purpose – we will be happy to assist you!*

I. SETUP

To set up dynamic electricity prices, log in to the portal after completing the installation routine. Then click on the gear icon on the left to access the system settings. Scroll down until you see the "Dynamic electricity tariff beta test" window and click on "SET UP" to start the setup.

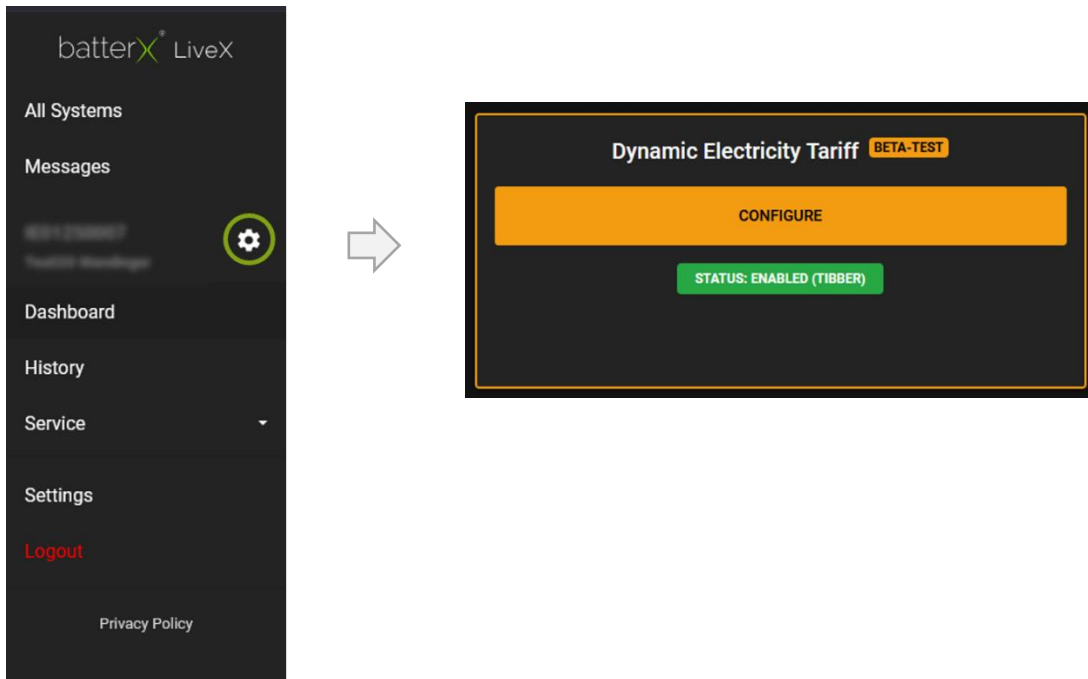

The following window will open:

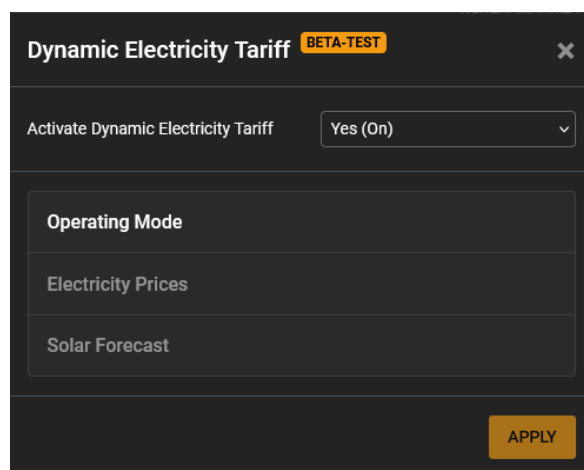

The tabs "Operating modes," "Electricity prices," and "Solar forecast" can be expanded by selecting them. **IMPORTANT:** The tabs must be filled in the specified order before the next one can be opened.



ACTIVATE DYNAMIC ELECTRICITY TARIFF

To set this up, select "Yes (On)" from the pull-down menu. You can now click on the "Operating modes" tab.

If you want to switch off price-based control at a later date, for example because you are switching back to a fixed electricity tariff, you can select "No (Off)" in this pull-down menu and click on "APPLY."

OPERATING MODES

Here you can set the "Battery charging from the mains." Use the pull-down menu to select between "Dynamically controlled" or "Always OFF." Please be sure to note the information text that appears when you select "Dynamically controlled"! Then click on "NEXT" to confirm your entry.

Dynamic Electricity Tariff BETA-TEST ✕

Activate Dynamic Electricity Tariff Yes (On) ▾

Operating Mode

Battery charging from the grid Dynamically Controlled ▾

By actively charging the battery from the grid at times when electricity prices are low, grid consumption at expensive times can be avoided.

ATTENTION: Active charging of the battery from the grid beyond the technically necessary trickle charge requires corresponding registration of the storage system. If in doubt, please contact your installer. By pressing the orange "Apply" button, you confirm that you have carried out this check.

Please note: To be eligible for a subsidy under the Renewable Energy Sources Act (EEG), the storage system must only store electricity generated from renewable energy sources and/or feeding. When this function is activated, the storage system is charged with grid electricity. Depending on the electricity supply contract, the grid electricity may also be generated from fossil fuels and/or nuclear power. Therefore, we cannot guarantee that the storage system will only be charged with electricity from renewable energy sources and/or feeding.

CONTINUE

Electricity Prices

Solar Forecast

APPLY

The "Operating mode" tab will automatically minimize and the "Electricity prices" tab will open.

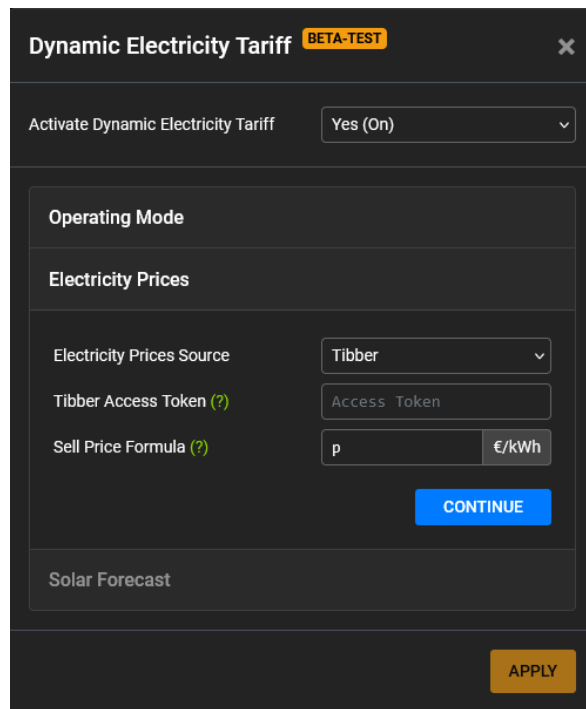

ELECTRICITY PRICE SOURCE:

Please select the electricity price source to be taken into account. If your provider is not listed, please select "ENTSO-E."

PRICE SOURCE: TIBBER

If you are a Tibber customer, please select "Tibber" as the electricity price source. The Tibber Access Token is required for integration. You can obtain this by clicking on the green question mark (?). You will be automatically redirected to the Tibber website. You can obtain your personal token by logging in with your access data.

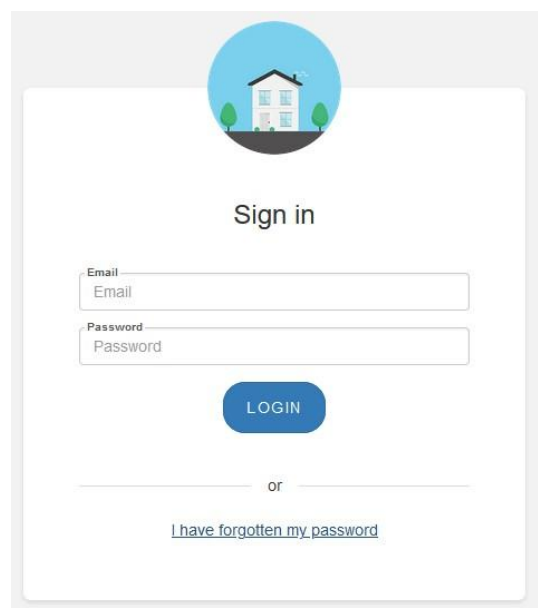
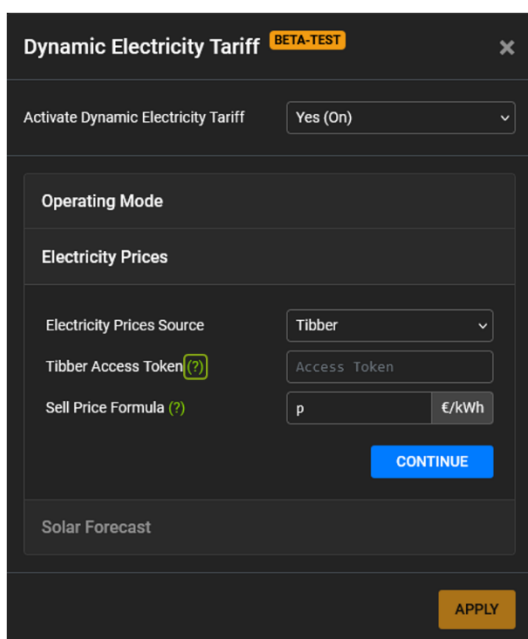

The screenshot shows the Tibber authorization interface. On the left, a sidebar menu is open to 'Authorization', with sub-items 'Access Token' and 'OAuth'. The main content area is titled 'Access Token' and contains the text: 'You'll need an Access Token if you want to use the API to access just your data in your own app. If you intend to make an integration available publicly, and therefore need to access other people's Tibber data, you will need to set up OAuth instead.' A blue button labeled 'Get a token' is highlighted with a yellow box. A grey arrow points downwards from this button.

This screenshot shows the 'Select the scopes you need' step of the Tibber authorization process. The sidebar menu is the same as in the previous screenshot. The main content area is titled 'Access Token' and 'Select the scopes you need'. A list of scopes is shown with checkboxes: **tibber_graph**, **user**, **homes**, **price**, **consumption**, **full**, and **write_access**. All checkboxes are checked. Below the list are two buttons: 'Create token' (highlighted with a yellow box) and 'Cancel'. A grey arrow points downwards from the 'Create token' button.

Copy the access token to the clipboard by clicking "Copy to clipboard" and then paste it into the designated field.

This screenshot shows the final step of the Tibber authorization process. The sidebar menu is the same. The main content area is titled 'Access Token' and contains the text: 'Your Access Token enables access to your private Tibber data and should be treated like a password. Handle with care!'. Below this text is a grey box containing a blurred access token. A blue button labeled 'Copy to clipboard' is highlighted with a yellow box. Below this is the section 'Approved scopes' with a list of scopes: **tibber_graph**, **user**, **homes**, **price**, **consumption**, **full**, and **write_access**. At the bottom of this section is a red button labeled 'Delete token'.

SALES PRICE FORMULA

Clicking in the field provided will open a new window.

You can select the following values from the pull-down menu:

- Spot Price (p), which corresponds to the actual market price of electricity.
- Total Buy Price (t) corresponds to the exchange price of electricity + ancillary costs, not relevant for Germany.
- Fixed Price. Select this option if, for example, you receive EEG remuneration for electricity fed into the grid. Now enter your feed-in tariff.

Use your own formula

Alternatively, you can click on "MANUAL INPUT" to open another window. Here you can now select your own calculation formula.

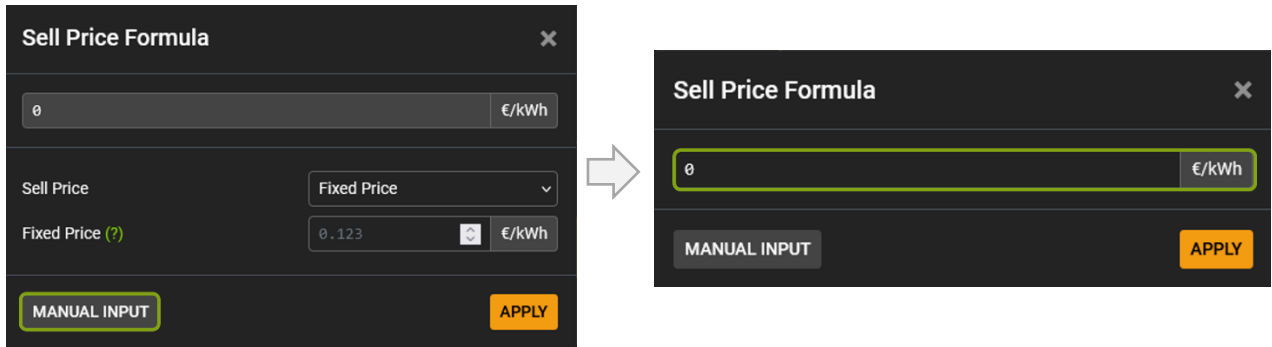

Click on "APPLY" to confirm your entries and proceed to the next tab, "Solar forecast."

PRICE SOURCE: ELECTRICITY EXCHANGE / OTHER PROVIDERS

If you would like to include other electricity price providers, please select "ENTSO-E" from the pull-down menu under "Electricity price source." Then select your zone/country under "Bidding Zone." The electricity prices for your zone will now be imported automatically.

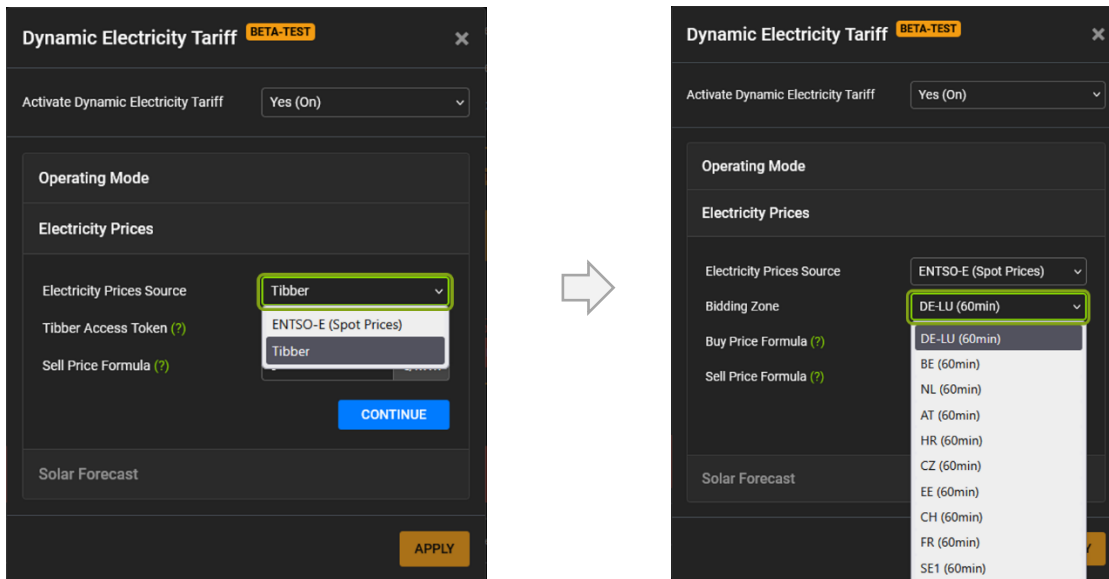

Code	Zone / Country	Code	Zone/Country
DE-LU	Germany-Luxembourg	CH	Switzerland
BE	Belgium	FR	France
NL	Netherlands	SE1	Sweden, Zone 1
AT	Austria	SE2	Sweden, Zone 2
HR	Hungary	SE3	Sweden, Zone 3
CZ	Czech Republic	SE4	Sweden, Zone 4
EE	Estonia	ES	Spain

If your zone/country is not yet available in the list, please contact us!

PRICE INTERVAL

Depending on the electricity price zone and tariff, you can additionally specify whether hourly or quarter-hourly prices should be taken into account.



Note: Please be aware that this option is not available in every country or electricity price zone, and not with every electricity tariff. Be sure to compare this setting with your personal dynamic electricity tariff. You can obtain this information from your electricity provider.

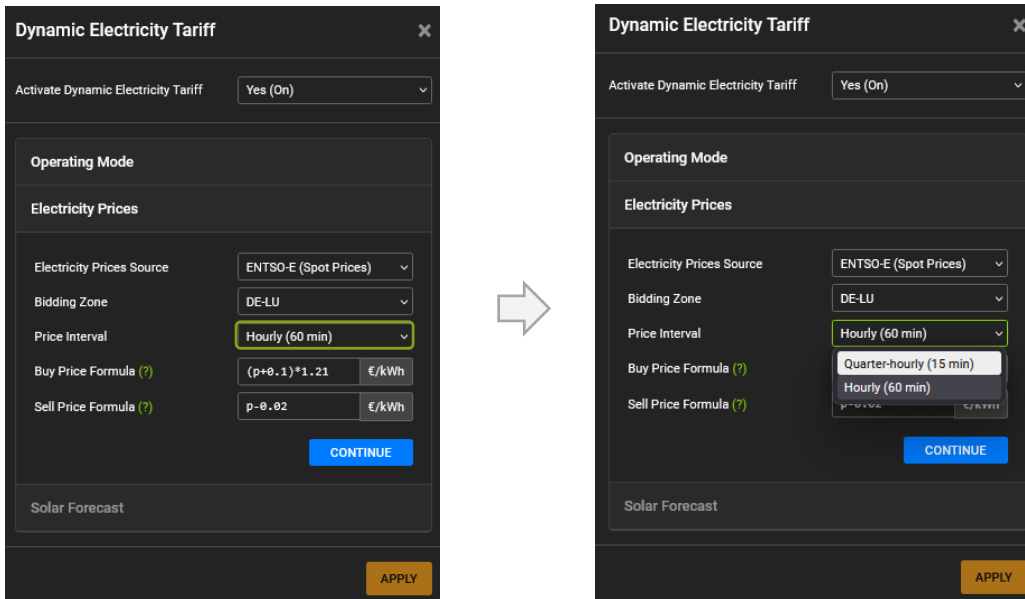

PURCHASE PRICE FORMULA

The image shows two screenshots of a software interface. The left screenshot is titled 'Dynamic Electricity Tariff BETA-TEST'. It has a toggle for 'Activate Dynamic Electricity Tariff' set to 'Yes (On)'. Under 'Electricity Prices', the 'Buy Price Formula (?)' field is highlighted with a green box and contains the value 'p'. Below it is a 'CONTINUE' button. The right screenshot is titled 'Buy Price Formula'. It shows a large input field at the top with 'p' and '€/kWh'. Below are fields for 'Spot Price' (p, €/kWh), 'Additional Costs (?)' (0.123, €/kWh), and 'Value Added Tax' (19, %). At the bottom are 'MANUAL INPUT' and 'APPLY' buttons.

Enter the relevant additional costs for the purchase/supply of electricity in the "Additional costs" field. These include network charges, levies, etc. and may vary from country to country or zone to zone and change over time.

Then enter the VAT for your country/zone. Alternatively, you can open another window by clicking "MANUAL INPUT" and enter the purchase price formula manually. Click "APPLY" to confirm your entries and close the window.

SELL PRICE FORMULA

Clicking in the field provided opens a new window

The image shows two screenshots. The top screenshot shows the 'Sell Price Formula (?)' field in the settings, highlighted with a green box and containing the value 'p'. An arrow points down to the second screenshot, which is a detailed 'Sell Price Formula' window. It has a large input field at the top with 'p' and '€/kWh'. Below it is a 'Sell Price' dropdown menu with 'Spot Price (p)' selected. At the bottom are 'MANUAL INPUT' and 'APPLY' buttons.

You can select the following values from the pull-down menu:

- Sport Price (p), which corresponds to the actual exchange electricity price.
- Total Purchase Price (t), corresponds to the exchange price of electricity + additional costs, not relevant for Germany.
- Fixed Amount. Select this option if, for example, you receive EEG remuneration for electricity fed into the grid. Now enter your feed-in tariff.



Use your own formula

Alternatively, you can click on "MANUAL INPUT " to open another window. Here you can now select your own calculation formula.



Click on "APPLY" to confirm your entries. Click on "NEXT" to close the "Electricity prices" tab and proceed to the next tab, "Solar forecast."

Solar forecast

To forecast the electricity generation of the PV system, we first need the system location. Clicking on the green (?) will automatically take you to the website www.latlong.net. Here you can determine the exact geo-data by entering the installation address. Alternatively, you can click on the existing map to mark a location. Copy the calculated geo data into the fields provided. *Note: Latitude = latitude; longitude = longitude*



Latitude and Longitude Finder

Latitude and Longitude are the units that represent the coordinates at geographic coordinate system. To make a search, use the name of a place, city, state, or address, or click the location on the map to find lat long coordinates.

Place Name

Add the country code for better results. Ex: London, UK

Latitude Longitude

[f](#) [t](#)

For better accuracy please type Name Address City State Zipcode.



Latitude and Longitude Finder

Latitude and Longitude are the units that represent the coordinates at geographic coordinate system. To make a search, use the name of a place, city, state, or address, or click the location on the map to find lat long coordinates.



You will then be asked to provide various details about your PV strings. You can enter information for up to 3 PV strings. Please enter the following data:

- Installed power of the PV modules in kWp.
- The tilt angle of the modules; usually the roof pitch, between 0° = horizontal and 90° = vertical.
- Orientation of the system (cardinal direction) as a numerical value. The following applies:

Compass direction	Orientation in degrees
North	0
North-northeast	2
Northeast	45
East-northeast	67.5
East	90
East-southeast	112.5
Southeast	135
South-southeast	157.5
South	180
South-southwest	202.5
Southwest	225
West-southwest	247.5
West	270
West-northwest	292.5
Northwest	315
North-northwest	337.5



Note: You can also enter the data for an external PV system here!

Confirm your entries by clicking on "CONTINUE." The "Solar forecast" tab will now be minimized. Clicking on "APPLY" will open a pop-up window. If you now click on "OK," your settings will be finalized and sent to the system.

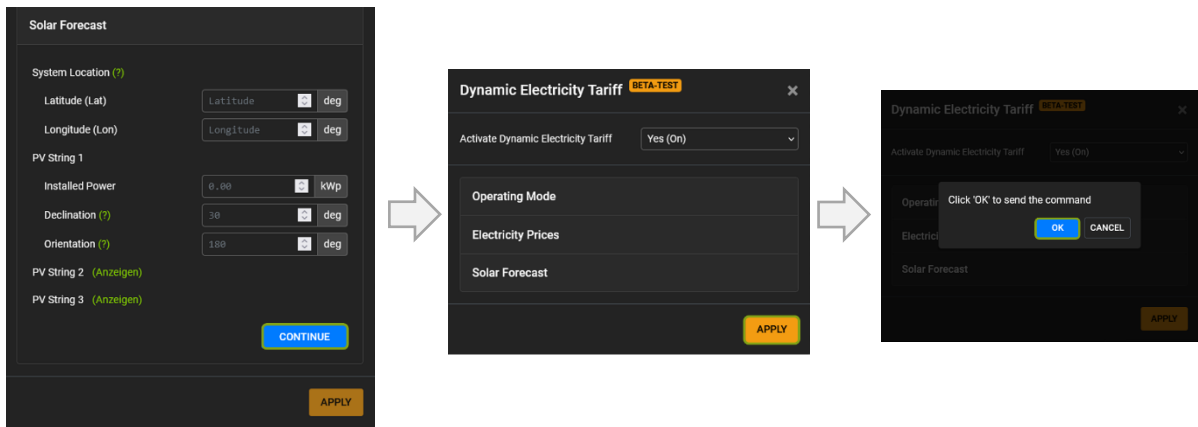

You have successfully completed the setup!
The system is now able to respond optimally to dynamic electricity prices.

II. DISPLAY IN THE PORTAL

After successfully setting up the dynamic electricity tariffs, you will see a new icon on the system tile:

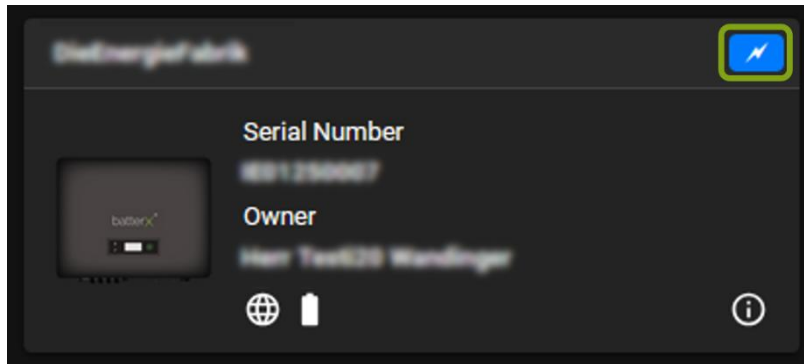

The main view in the dashboard remains unchanged.

History

If you click on "History" in the left-hand menu, you will be taken to the familiar view. There is now a new icon in the upper right-hand corner. Clicking on it will take you to a new view.

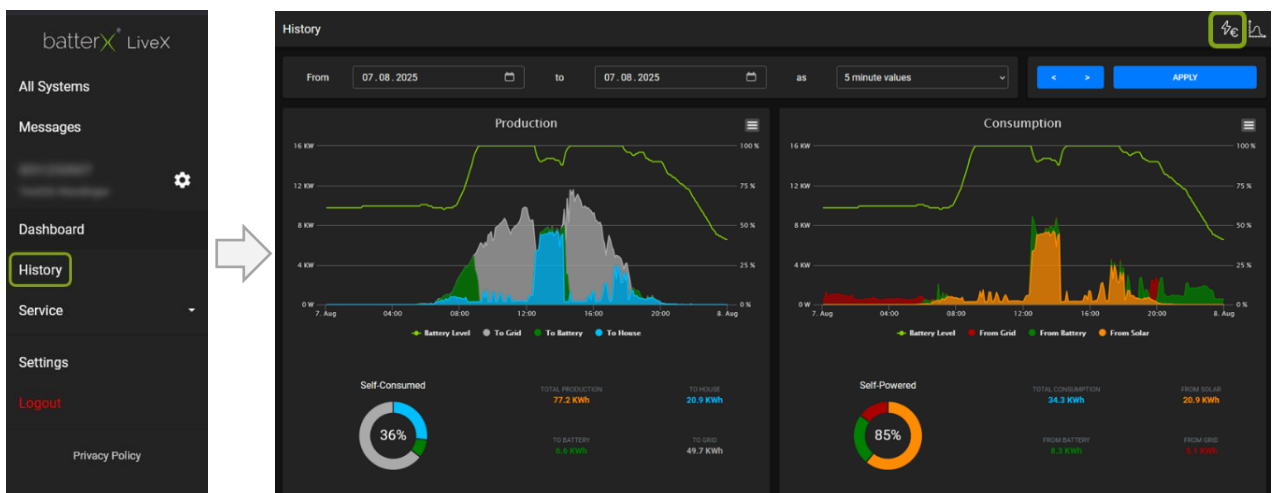



- 1. Select period:** Here you can adjust the period to be displayed.
- 2. Main display area:** This area contains the most important information.
 - Red: Purchase price of electricity based on your specifications (seeSetup)
 - Gray: Selling price of electricity based on your specifications (seeSetup)
 - Green: Charge status of the battery storage
- 3. Current time:** This vertical line indicates the current time (here: approx. 15:45) and moves from left to right as the day progresses. It separates historical data on the left from forecast data on the right.
- 4. Operating mode:** This shows the operating mode of the system over time.
 - Gray: Normal operating mode: The system is operating in normal mode.
 - Green: Active dynamic control: The system is actively controlled, and its behavior is optimized.

9. TIME-CONTROLLED BATTERY CHARGING



The settings explained in this chapter can only be configured by the installer or batterX itself. As an end customer, please contact your installer.

batterX enables the battery storage unit to be charged from the grid at fixed times. To set up the control system, log in to the portal after completing the installation routine. Then click on the gear icon on the left-hand side to access the system settings. Click on "BATTERY CHARGING AC" to access the setup.

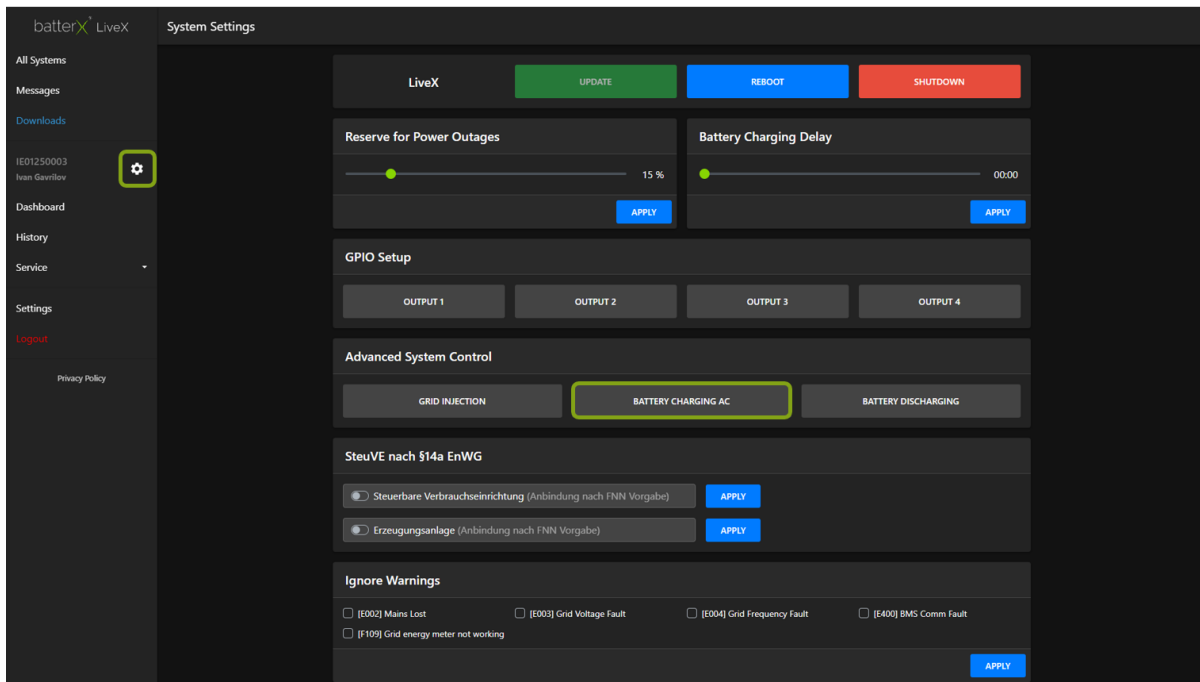

Select "Enable when" from the pull-down menu and a settings window will open.

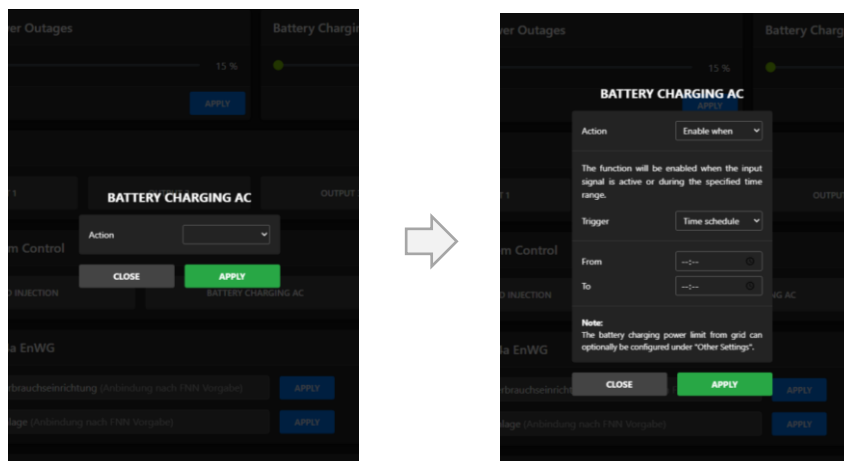

- 1. Action:** Here you can enable or disable the AC battery charging.
- 2. Trigger:** **Time schedule:** Select "Time schedule" if you want to use the AC battery charging for a specific time period.
From ... To: Enter the desired period during which AC battery charging should be activated, for example from 02:00 to 04:00 am.



Please note: During this period, AC battery charging is constantly activated, and the system attempts to charge the storage unit from the grid. batterX recommends selecting times that allow the storage unit to be fully charged once. To do this, the capacity of the storage unit and the charging power must be taken into account.



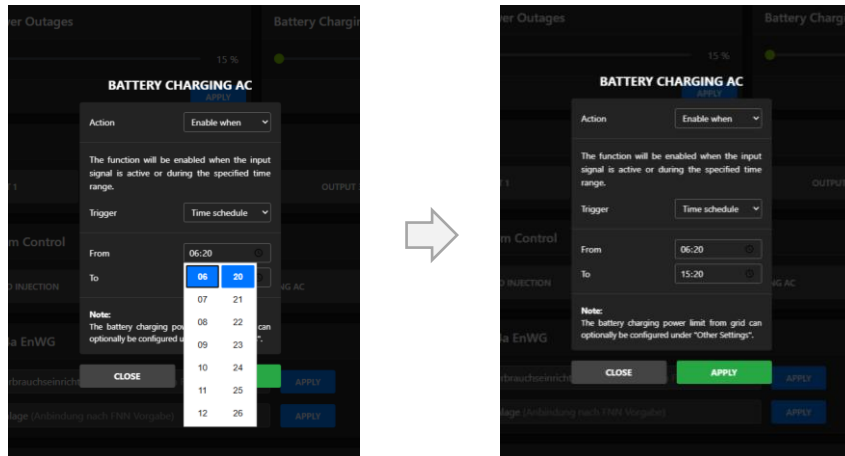

Then click "APPLY" to save the settings.

Optional power limitation

By default, the batteries are charged at C0.5. This means, for example, that a 10 kWh storage unit is charged at 5 kW. To increase the service life of the batteries, it is advisable to reduce the charging power and charge the storage unit over a longer period of time to protect the batteries. You can set this power limit in the system settings. To do this, click on the gear icon on the left-hand side to open the settings. Then scroll down to the 'Other settings' section. Tick the box next to "Limit battery charging power from grid" and then enter the desired charging power in Watts. Finally, click on "Apply" to save your settings.

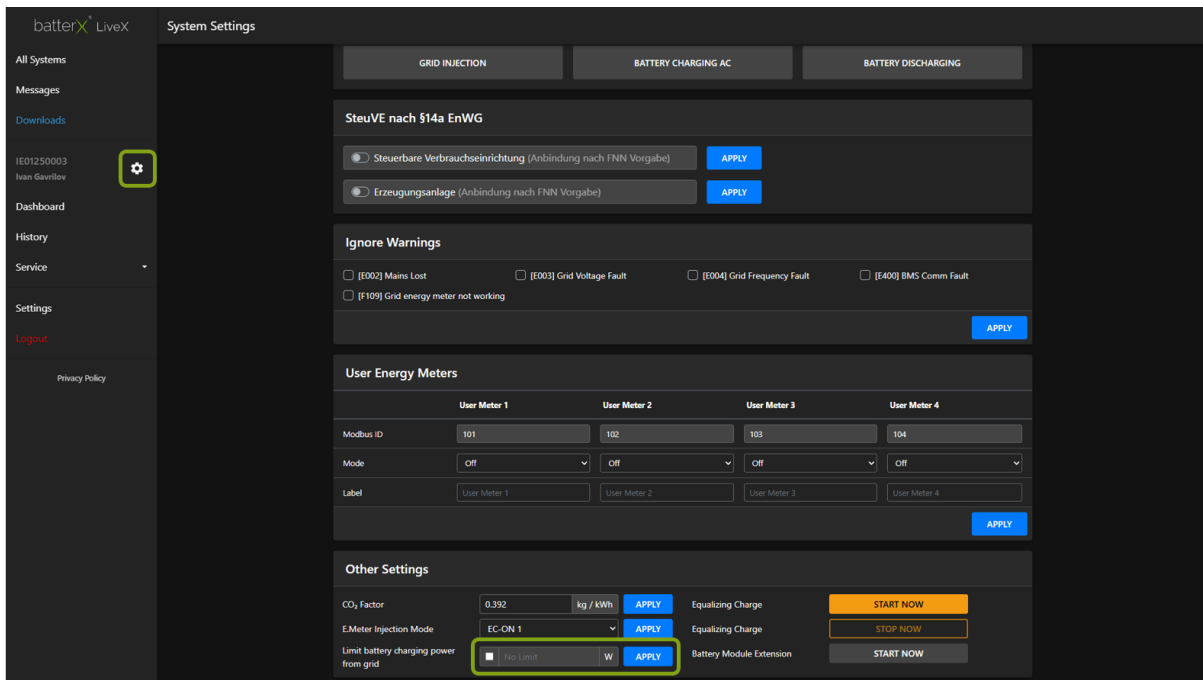

10. SIGNAL-CONTROLLED BATTERY CHARGING



The settings explained in this chapter can only be configured by the installer or batterX itself. As an end customer, please contact your installer.

batterX enables active control of battery charging from the grid via an input signal. To set up the control, log in to the portal after completing the installation routine. Then click on the gear icon on the left-hand side to access the system settings. Click on 'BATTERY CHARGING AC' to access the setup.

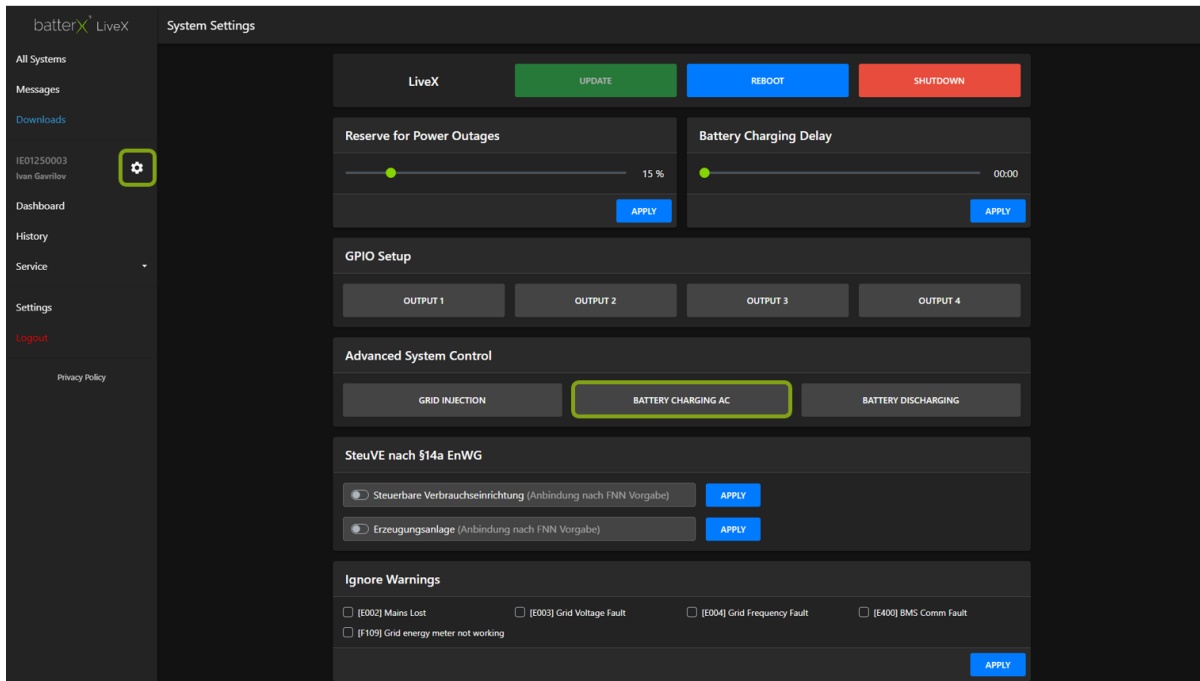

Select "Enable when" from the pull-down menu and a settings window will open.

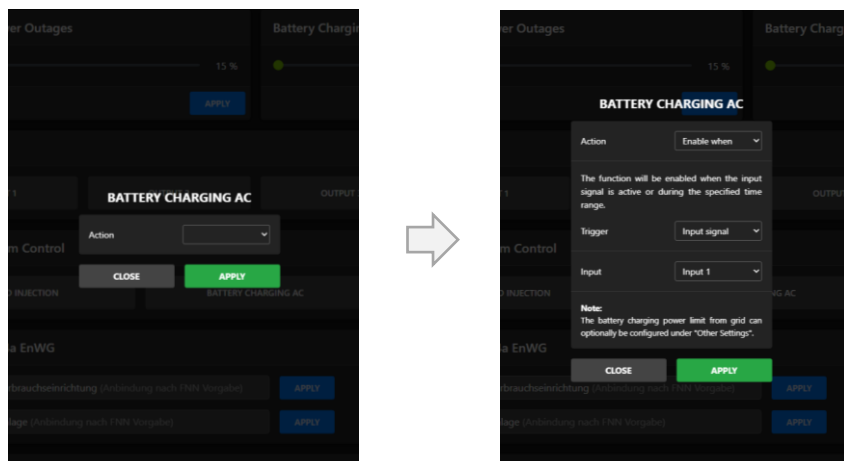

1. **Action:** Here you can enable or disable the AC battery charging.
2. **Trigger:** **Input signal:** You can activate AC battery charging via a controlled input (GPIO). To do this, select 'Input signal' in this field and the desired input in the field below. A description of the wiring for these inputs can be found in Chapter III EMX.



Please note: AC battery charging is activated as long as the input signal is active. The system will attempt to charge the storage unit from the grid. batterX recommends controlling the input signal so that the storage unit can be fully charged once. To do this, the capacity of the storage unit and the charging power must be taken into account.



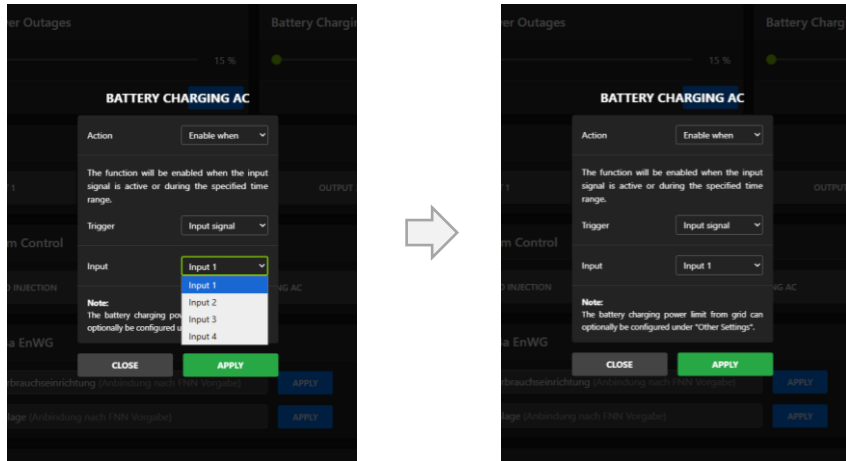

Then click "APPLY" to save the settings.

Optional power limitation

By default, the batteries are charged at C0.5. This means, for example, that a 10 kWh storage unit is charged at 5 kW. To increase the service life of the batteries, it is advisable to reduce the charging power and charge the storage unit over a longer period to protect the batteries. You can set this power limit in the system settings. To do this, click on the gear icon on the left-hand side to open the settings. Then scroll down to the 'Other settings' section. Tick the box next to "Limit battery charging power from grid" and then enter the desired charging power in watts. Finally, click on "Apply" to save your settings.

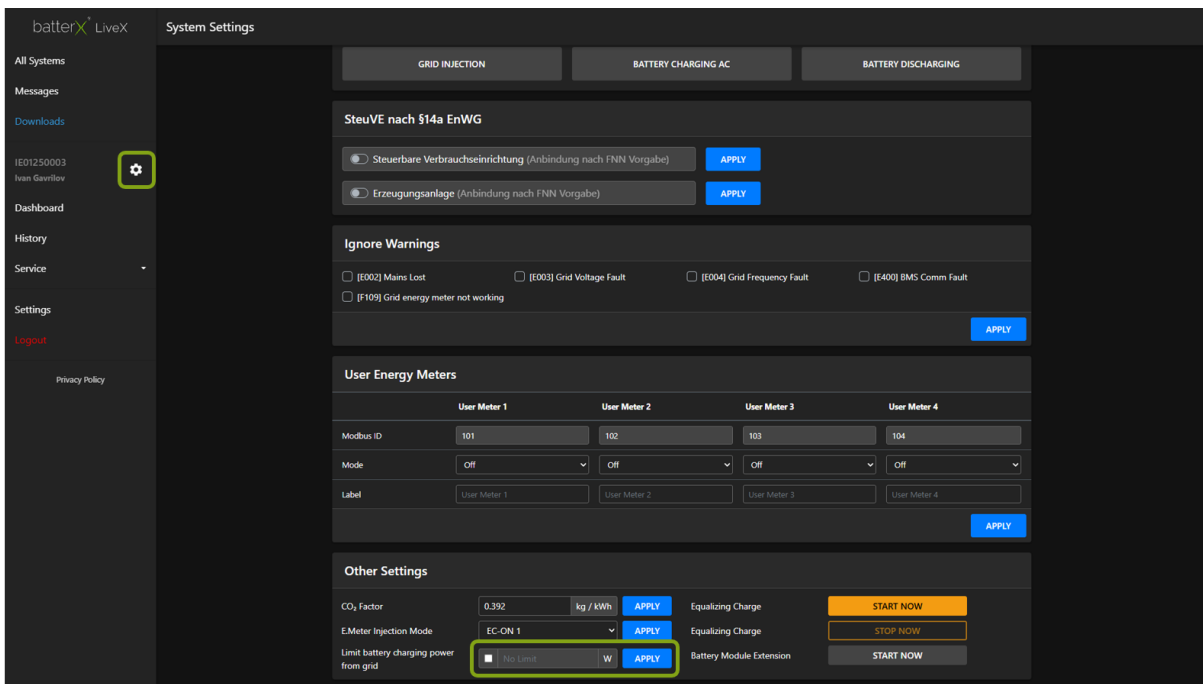

11. WARRANTY PROCESSING

If a defect is detected on a device, an automatic warranty report can be created via the portal. To do this, open the "Overview" menu in the installer's account, which is located in the "Service" area.

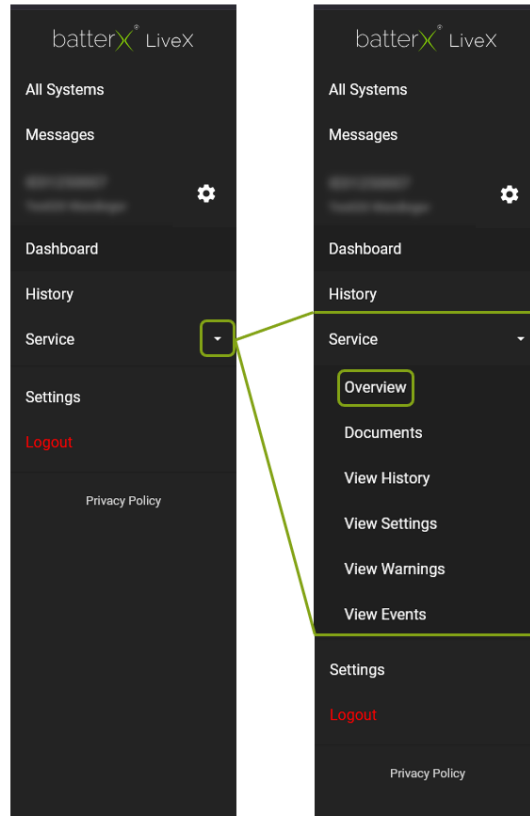

1. Create warranty report: Press the orange button at the bottom left of the overview to open the warranty report.

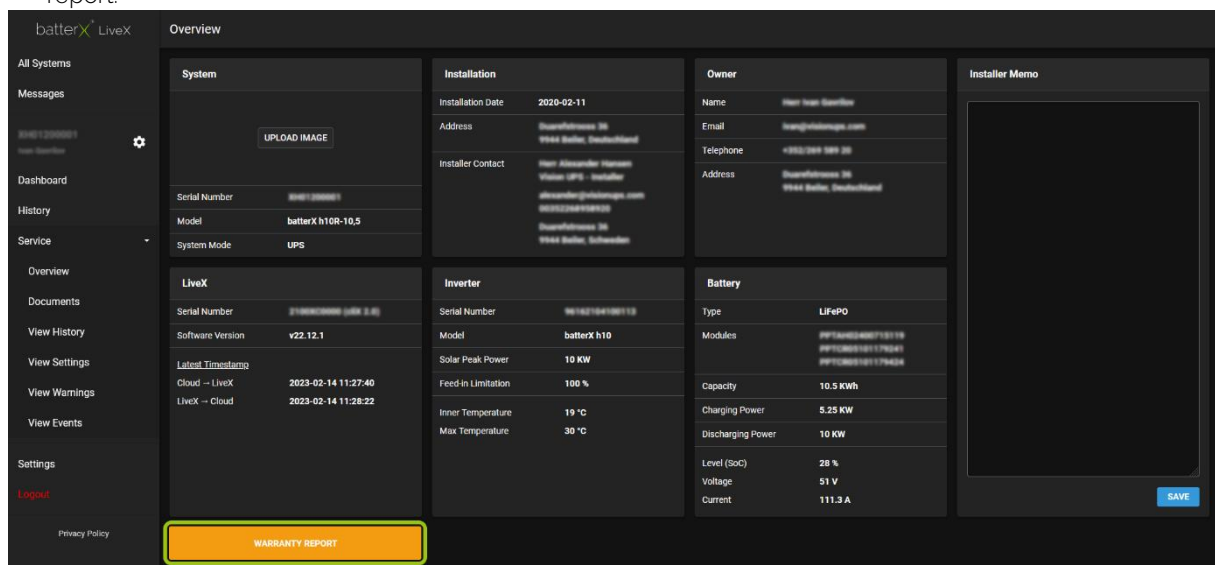



2. Fill out warranty report: Most of the data in the warranty report is already filled in automatically. However, the following information must be entered manually:

- **Error occurrence date:** Date on which the error occurred. If the exact date cannot be determined, an estimate can be entered here.
- **Faulty component(s):** Component(s) of the system that is/are defective.
- **Number of components:** Specify how many of the above mentioned components are defective.
- **Serial number(s) of the component(s):** Serial number(s) of the defective component(s). The number of serial numbers should match the "Number of components."
- **Date of fault diagnosis:** Date on which the installer inspected the system on site.
- **Operating mode when the fault occurred:** Status of the system when the fault occurred. For example, during a power failure.
- **Description:** Description of the fault. The more detailed the description, the faster and easier it will be to process your request. The fault and warning codes of the inverter are also important here.
- **Request service fee:** A flat fee can be requested to compensate the installer for the service call in the event of a fault. The applicable warranty conditions must be observed.



3. Complete warranty report: Finally, the warranty and terms and conditions must be accepted before the report can be submitted.

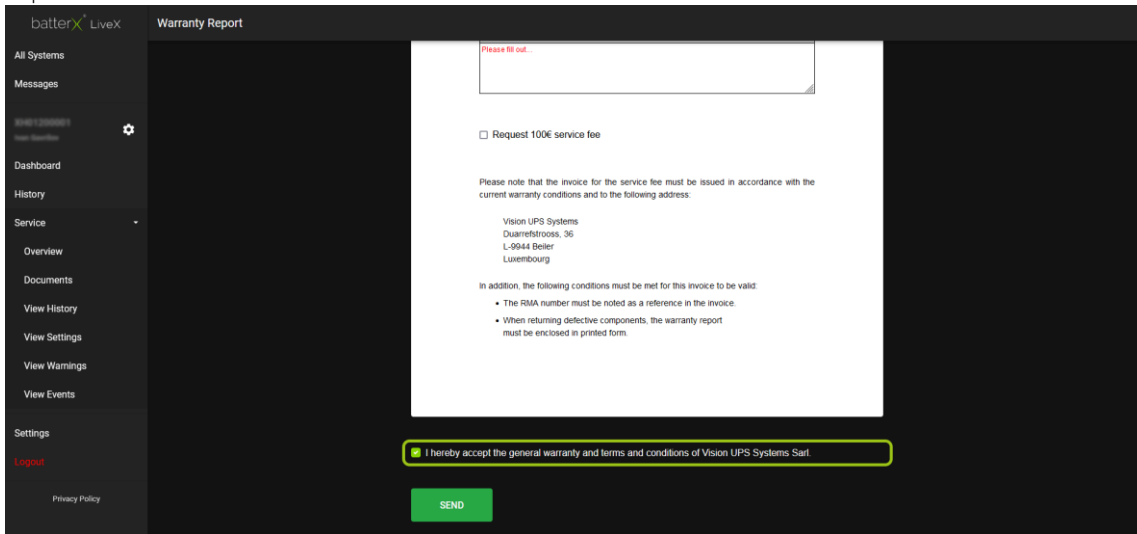

- **Input error:** If not all mandatory fields are filled in correctly.

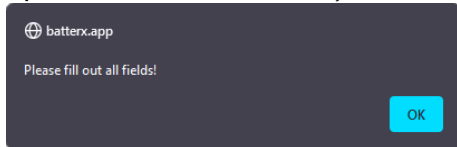

- **Successful completion:** This field indicates that the report has been sent successfully. No further steps are required.

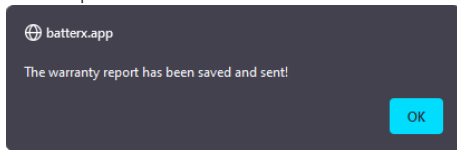

4. Download report (optional): After sending, you can also download the report as a PDF by pressing the new blue button.

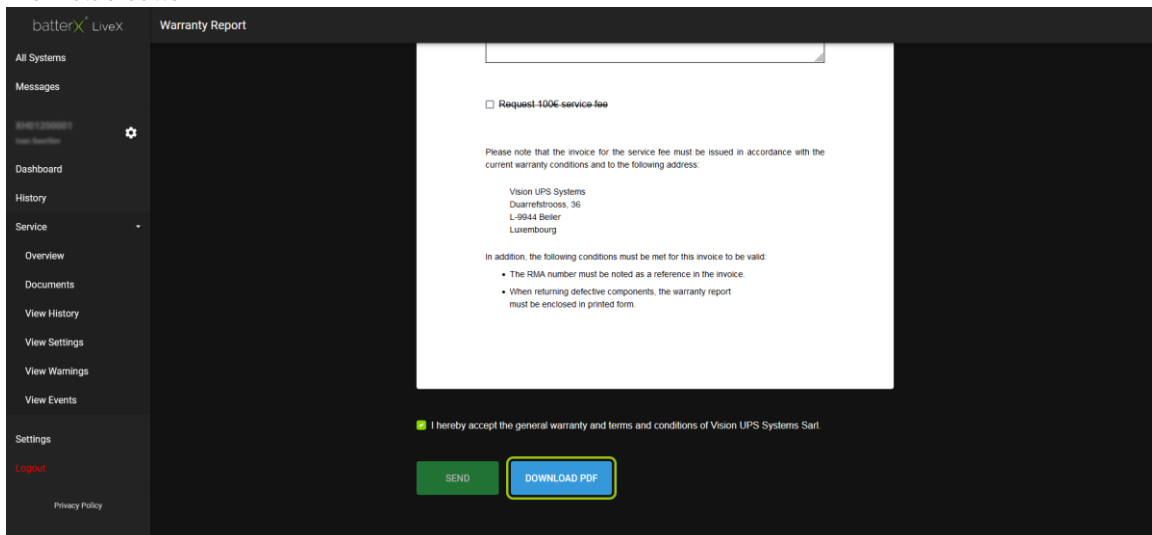

The warranty report can be viewed at any time in the portal under the "Documents" menu.

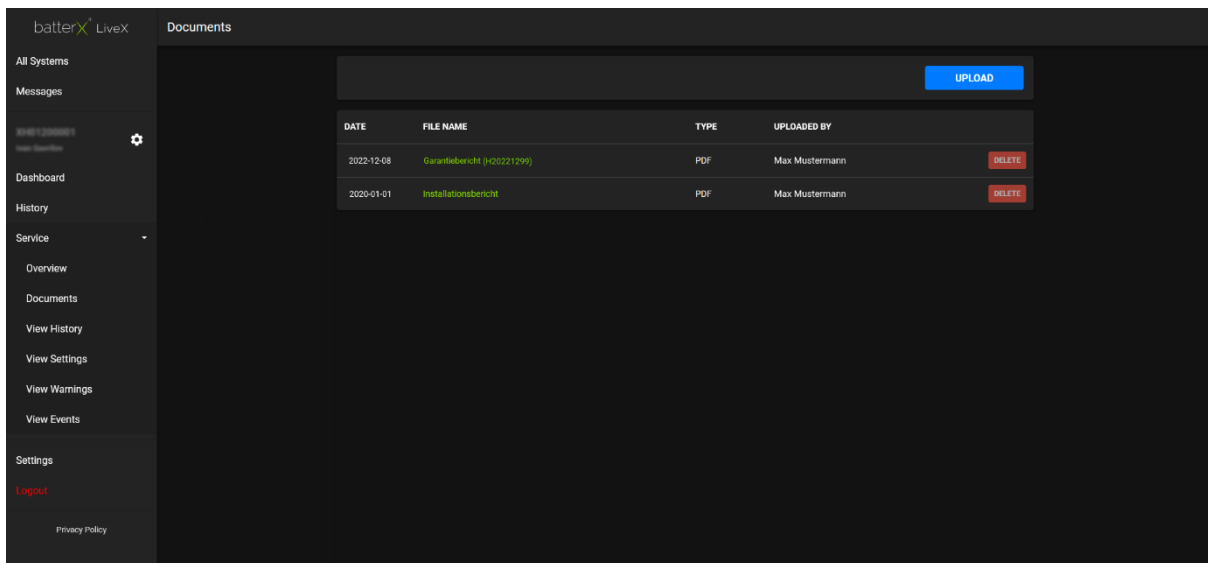

Once these steps have been completed and the warranty claim has been processed, you will receive a replacement for the defective component(s). Once the corresponding device has been replaced and the **installation routine has been successfully completed**, we will arrange for the defective component(s) to be collected from your branch, meaning the device must not remain with the end customer. To do this, please send an email with the following information to "info@visionups.com":

- RMA number
- Package/pallet
- Dimensions (L x W x H)
- Weight
- Pickup time (day and time or opening hours)

12. MAINTENANCE

Maintenance of the inverter & EMX



Improper operation may result in damage to the inverter or personal injury.



To avoid the risk of electric shock, the service technician should disconnect all AC and DC power sources from the system and check for any dangerous voltages before starting any work on the system. Simply switching off the device does not reduce the risk! The internal capacitors may remain charged for up to 10 minutes after the power sources have been switched off.



Keep unauthorized people away. Unauthorized people must be kept away during electrical connection and maintenance work by means of a temporary warning sign or barrier.



Do not replace internal components without authorization. Please contact batterX for maintenance support. Otherwise, batterX will not be liable.



Please do not perform any unauthorized maintenance work before you have familiarized yourself with the proper instructions for the entire process.

Please proceed exactly as follows.

- Select the "Stop" option on the inverter screen or the monitoring app to switch off the inverter.
- Switch off the AC circuit breaker on the mains side.
- Switch off the DC switch(es) of the inverter.
- Switch off the battery switch and the DC circuit breaker on the battery side (if present).
- Wait 10 minutes to ensure that the energy in the capacitor has been completely discharged.
- Make sure that all indicator lights are off.

Action	Methods	Period
Clean the system	Check the heat sink and air inlet and outlet for dust and/or foreign objects.	Once every 6 to 12 months
Electrical connections	Check that all cables are connected correctly.	Once every 6 to 12 months
Sealing	Check that all clamps and connections are well sealed. Re-seal the cable hole if it is not tight or the seal has aged.	Once a year

Maintenance of the battery storage unit & MULTI

The system must be serviced regularly, usually once a year. The intervals may vary or be shorter depending on the environmental conditions and usage. It must be ensured that the system is in proper condition, can function properly, and that the installation conditions are still met at a later date.



The installation and maintenance of batteries should be carried out or supervised by persons with specialist knowledge of batteries.



Do not throw the battery into a fire. Risk of explosion! Do not disassemble or break the battery. The electrolytes it contains are harmful to health.



The battery poses a risk of electric shock. Observe the following instructions during handling.

- Remove metal objects from your body.
- Use insulated tools.
- Remove metal parts from the battery installation area.
- Switch off the DC circuit breaker of the battery before installing or removing the battery terminals.
- There is a risk of electric shock if the battery terminals are unexpectedly grounded. Remove the grounding cable to prevent electric shock.

	Hazard warning sign
	Health hazard
	Very toxic to aquatic organisms

Activity	Methods	Period
Visual inspection	Visually inspect the battery system and all cables and connections for damage, deformation, discoloration, and signs of aging. Check the electrical connections.	Usually once a year
Cleaning	Carefully clean the battery system of dust and dirt using a dry cotton cloth. Do not use any corrosive or caustic cleaning agents. Ensure adequate ventilation.	Usually once a year
Connections	Check that the electrical connections and connecting screws are tight and retighten them if necessary. Check the cable temperature.	Usually once a year



13. EMERGENCY STOP FUNTION



To activate or change the emergency stop function, please contact batterX customer service! Only batterX can make these settings - we are happy to assist you.

The hybrid inverters of the batterX i-Series come standard with a stop function (emergency stop), but it must be activated by batterX. To use the emergency stop function, connect an external switch or button to the emergency stop interface. Use contacts 11 and 12 on the COM2 connector for this purpose. The external switch/button is not included in the accessory package.

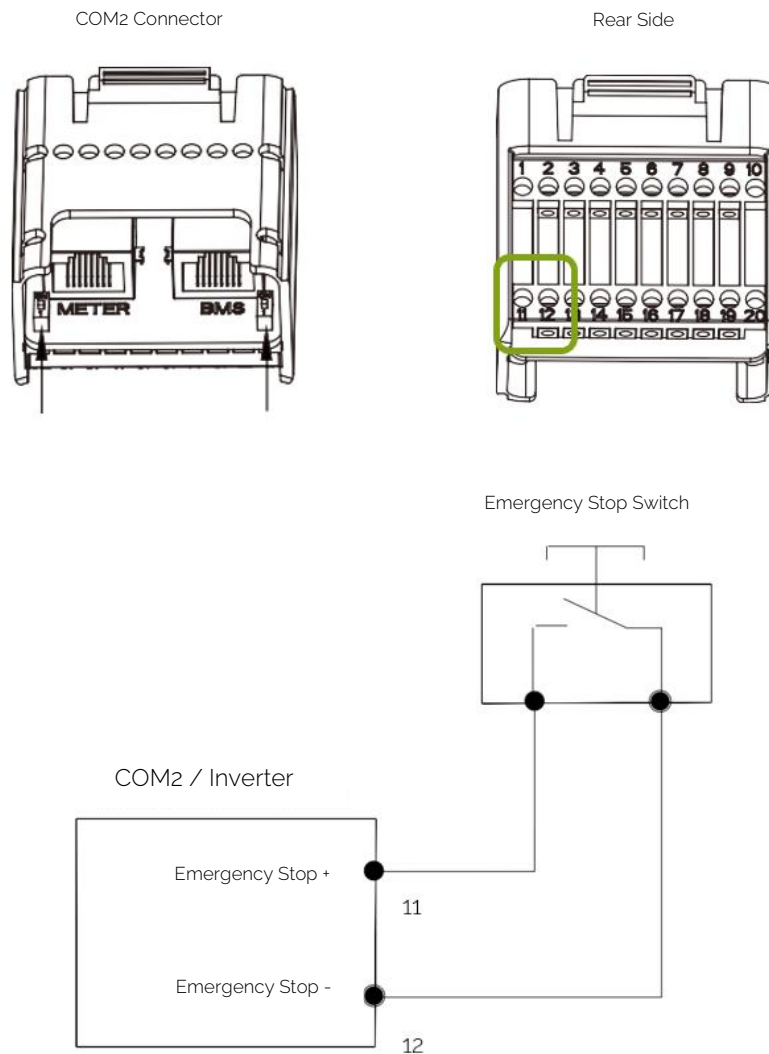

The emergency stop function can be implemented with either a normally closed (NC) or normally open (NO) contact. In both cases, it must be ensured that a corresponding emergency stop switch/button is connected and that the circuit is closed (for NC) or open (for NO). If this is not the case, the system will shut down after applying the setting, as it will appear that the emergency stop switch/button has been activated. If you want to change the function from NC to NO (or vice versa), you must first go through the intermediate step "Function Disabled."

1. Initiate state with NC or NO
2. Turn off the emergency stop function
3. Adjust the wiring
4. Turn on the emergency stop function with the new setting.

14. USE OF OPTIMIZERS

The inverters of the i-Series are compatible with the power optimizers from Tigo Energy. A list of compatible optimizers can be found on our website www.batterx.de or on request from our support team at info@batterx.de. Please observe the installation instructions for the individual products.

15. BATTERY EXPANSION

To ensure the best possible system performance, batterX recommends expanding the battery storage within the first 6 months after initial installation. This ensures that the maximum specifications of the system are fully utilized. Later expansions are also possible – however, please note that these expansions must be individually checked and approved by batterX.

When expanding the system, all existing and new battery modules must be 100% charged.

16. API UND MODBUS TCP/IP

The batterX system supports connectivity via both a REST API and Modbus-TCP/IP. Both interfaces allow you to read system data and control the system externally—for example, to integrate charging and discharging processes into a higher-level building automation system or an external energy management system.

A complete description of all available parameters, commands, and connection settings can be found at:

<https://api.batterx.app/docs>



For any further questions, please feel free to contact batterX customer service – we are happy to assist you!

17. CONTROLLABLE CONSUMPTION DEVICES

Quick guide to connecting SteuVE in accordance with Section 14a EnWG (German Energy Industry Act) in accordance with "FNN-2bit" direct control. Please note that this chapter only applies to installations in Germany!

Background

Power storage systems that went into operation on or after January 1, 2024, with a potential charging capacity > 4.2 kW from the grid are considered SteuVE (controllable consumption devices). If required, these power storage systems must limit their charging capacity to a maximum of 4.2 kW from the grid.

At the same time, generation systems from 0-25 kW/kWp must also be able to gradually adjust their power feed into the grid (100%/60%/30%/0%).

Several models for implementation and control have been developed.

Since both of the above-mentioned areas apply to the batterX i-Series, this manual describes both connections to an FNN control box for "FNN-2bit" direct control.

Controllable consumption devices

E2	E1	Consumption (§ 14a SteuVE / EMS)
0	0	Approval (unrestricted operation)
0	1	Guaranteed minimum value § 14a (dimming)
1	0	N.N (free)
1	1	Block

Generating plant

E	E1	Generation
0	0	100 %
0	1	60 %
1	0	30 %
1	1	0 %

Source: VDE FNN Impulse – Specification of a uniform interface on a controllable device or energy management system for connection to an FNN control box



Connection to the i-Series / EMX

The connection to the i-Series is made via the auxiliary contacts in the EMX and must be carried out as follows: The system has 4 inputs that can be configured via the batterX portal. The inputs are located in the EMX.

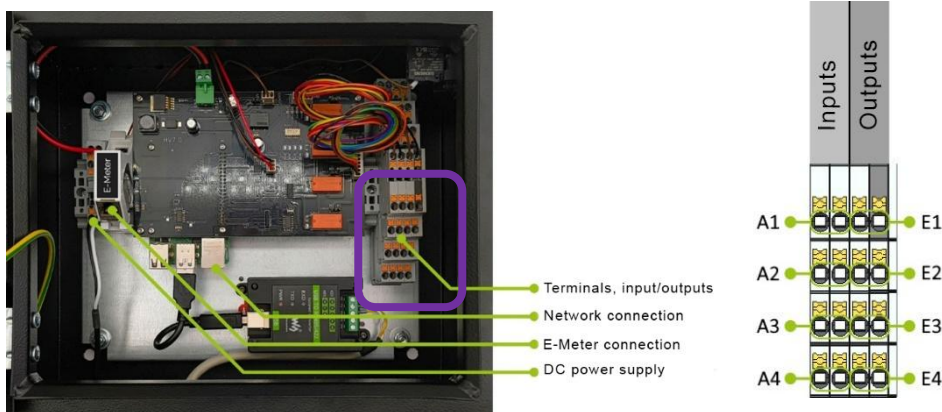

! No external voltages may be connected to these contacts.

The terminal assignment of the individual contacts is as follows. Permissible cross-sections of the individual terminals are:

- 0.14-4 mm² rigid
- 0.14-4 mm² flexible
- 0.14-2.5 mm² with ferrule (with or without plastic insulation)

Wire end ferrules and rigid cables can be easily inserted into the terminal. When connecting flexible cables and to disconnect all variants, the orange release must be pressed in first.

For direct control of the control unit in accordance with §14a EnWG, all 4 inputs must be connected so that the following circuits are taken into account:

- **Controllable consumption device**

Controllable consumption device		
FNN-2bit	Relay 2 (E2)	Relay 1 (E1)
batterX	Input 2 - G	Input 1 - G

- **Generation plant**

Generation plant		
FNN-2bit	Relay 2 (E2)	Relay 1 (E1)
batterX	Input 4 - G	Input 3 - G



18. BLACK START

The black start allows the system to start without an external grid supply and to activate the backup output. If the system shuts down during a power outage—e.g., due to an overload—you can use a black start to restore power to your protected loads from the battery system.

Prerequisites:

- Before performing a black start, ensure that all fuses and switches in the system are turned on.
- Make sure the protected output is not overloaded by too many consumers.
- The battery state of charge must be at least 15%; otherwise, a black start cannot be performed.

Black Start with a single Battery Tower

To start the system with a single battery tower:

1. Ensure all fuses and switches are turned on.
2. Press the BMS button on the battery tower for at least 3 seconds. The system will then start automatically.

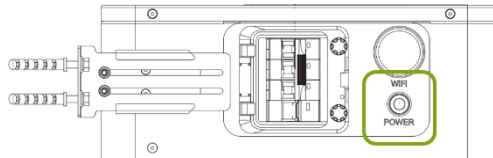

3. Wait until the inverter display lights up. Starting the inverter may take a moment. Once started, the protected output will be powered by the system.

Black Start with Multiple Battery Towers (MULTI Mode)

To start the system with multiple battery towers in MULTI mode:

1. Ensure all fuses and switches are turned on.
2. Start the MULTI by turning on the LS switch (2) (top position) and pressing the button (1). The ring LED around button (1) will light up.

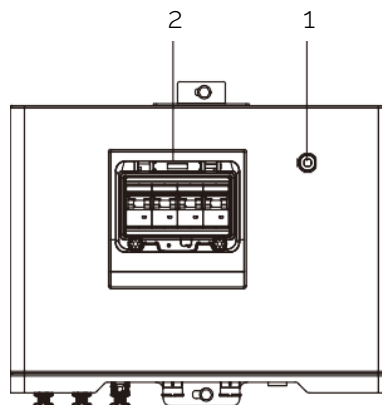

3. Press the BMS button on the first battery tower for at least 3 seconds.

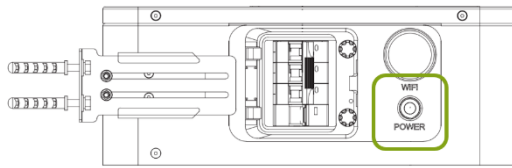

4. Wait until the inverter display lights up. This process can take 5–10 minutes.
5. Press and hold the display button on the inverter for at least 20 seconds.
6. The inverter will switch on, and the entire system will become operational.

19. ERROR CODES

Code	Message	Description	Remedy
E002	Power failure	Power failure in the mains or AC switch or circuit is interrupted.	<ol style="list-style-type: none"> 1. Check whether the mains supply is interrupted. 2. Check whether the AC circuit breaker has tripped. 3. Check whether the AC cable is wired correctly.
E003	Mains voltage error	The inverter detects that the grid voltage exceeds the limit value of the selected safety limit value.	<ol style="list-style-type: none"> 1. Check whether the mains setting is correct. 2. Check that the AC cable is wired correctly. 3. Check whether the voltage has risen due to high impedance of the AC line. In this case, a thicker AC cable could be used. 4. Extend the voltage protection limit with the approval of the power supply company.
E004	Mains frequency error	The inverter detects that the AC frequency exceeds the limit of the selected safety range. If occasional mains fluctuations cause this error, the inverter will automatically reset itself.	<ol style="list-style-type: none"> 1. Check that the mains setting is correct. 2. Extend the voltage protection limit with permission from the power supply company.
E005	DC feed error	The inverter detects that the DC feed-in value exceeds the limit range.	<ol style="list-style-type: none"> 1. Restart the inverter. 2. Contact the installer or manufacturer for assistance.
E006	Insulation error	The inverter detects that the insulation impedance of the DC side to ground is too low.	<ol style="list-style-type: none"> 1. Check whether PV modules, cables, and connectors are wet or damaged. 2. Use a measuring device to measure the grounding resistance on the DC side. The measured value should not be less than 500 KΩ. 3. Contact the installer or manufacturer.
E007	Fault current too high	The inverter detects that the earth fault current exceeds the limit value.	<ol style="list-style-type: none"> 1. Restart the inverter. 2. Check whether the PV modules, cables, and connections are wet or damaged. 3. Contact the installer or manufacturer.
E008	PV overvoltage	The PV input voltage exceeds the upper limit.	<ol style="list-style-type: none"> 1. Reduce the number of PV modules to ensure that the open-circuit voltage of each string is below the maximum permissible input voltage of the inverter.
E001	DC BUS overvoltage	The DC bus voltage exceeds the upper limit.	<ol style="list-style-type: none"> 1. Check whether the DC input voltage exceeds the limit value. 2. Restart the inverter. 3. Contact the installer or manufacturer.
E009	Overheating	The inverter detects that its internal temperature is high.	<ol style="list-style-type: none"> 1. Check that the inverter installation site is well ventilated. 2. Switch off the device for a while and switch it back on again when it has cooled down. 3. Contact the installer or manufacturer.
E010	N-PE check error	The grounding cable is loose or has poor contact on the backup side.	<ol style="list-style-type: none"> 1. Check that the grounding cables are connected correctly. 2. If no grounding is required, the N-PE check function can be disabled.
E030	DC arc fault	The DC part of the inverter has arc problems.	<ol style="list-style-type: none"> 1. Check whether there is any damage caused by arcing or cables on the DC side. 2. Restart the inverter. 3. Contact the installer or manufacturer.
E033	DC BUS voltage imbalance	Inverter current fluctuations leading to an imbalance in the bus output power, or damaged IGBT.	<ol style="list-style-type: none"> 1. Restart the inverter. 2. Contact the installer or manufacturer.
E020	SPI error	DSP communication interruption	<ol style="list-style-type: none"> 1. Restart the inverter. 2. Contact the installer or manufacturer.
E021	E2 Error	EEPROM chip damaged	<ol style="list-style-type: none"> 1. Restart the inverter. 2. Contact the installer or manufacturer.
E022	GFCI sensor error	Fault in the GFCI sensor	<ol style="list-style-type: none"> 1. Restart the inverter. 2. Contact the installer or manufacturer.
E023	AC sensor error	Current sensor detection circuit abnormal.	<ol style="list-style-type: none"> 1. Restart the inverter. 2. Contact the installer or manufacturer.
E024	Relay error	Relay damaged	<ol style="list-style-type: none"> 1. Restart the inverter. 2. Contact the installer or manufacturer.
E025	Internal fan error	The internal fan is damaged, the power supply is insufficient.	<ol style="list-style-type: none"> 1. Restart the inverter. 2. Contact the installer or manufacturer.



E026	External fan error	The external fan is damaged, the power supply is insufficient, or the air duct is blocked.	Check whether the fan is blocked by foreign objects and clean it if necessary.
E032	Bus voltage 'Hard' error	The energy flow to the DC bus exceeds the energy outflow.	1. Check whether the input voltage on the DC side exceeds the limit value. If this is the case, please change the configuration on the DC side. 2. Contact the installer or manufacturer.
E012	Battery voltage error	The battery voltage exceeds the upper limit.	1. Check whether the DC input voltage is outside the permissible range. 2. Check whether the battery switches off when the error occurs.
E013	Voltage error at emergency power output	1. Abnormal voltage input on the backup side. 2. Internal relay on the backup side is damaged.	1. Check whether the backup side is connected to a power supply. 2. Restart the inverter.
E028	DC-BUS voltage low	The DC BUS voltage is too low	1. Reduce the load on the backup side 2. Check the load capacity/discharge capacity of the battery
E014	Hardware error	Unknown hardware error	1. Restart the inverter. 2. Contact the installer or manufacturer.
E015	Protected output load error	The load on the backup side is overloading the discharge capacity.	1. Reduce the load on the backup side 2. Check the load capacity/discharge capacity of the battery
E016	Inverter overvoltage	1. During off-grid operation, the voltage on the backup side exceeds the safety regulations 2. Internal circuit malfunction	1. Check whether there is a surge load (high starting current) on the backup side and whether the load power is too high. 2. Check whether there is a short circuit on the backup side.
E011	Inverter overfrequency	The load exceeds the limit range of the inverter in off-grid mode.	1. Check whether there is a peak load (high starting current) on the backup side and whether the load power is too high. 2. Check whether there is a short circuit on the backup side.
E017	Inverter overcurrent	Abnormal load on the backup side during off-grid operation.	1. Check whether there is a surge load (high starting current) on the backup side and whether the load power is too high. 2. Check whether there is a short circuit on the backup side.
E037	Incorrect rotating field or phase loss at the mains input	1. Abnormal phase sequence of the mains voltage. 2. Anomaly in voltage measurement.	1. Check whether the current on the backup side exceeds the limit value. 2. Change the phase sequence of the supply cable. 3. Restart the inverter. 4. Contact the installer or manufacturer.
E034	Protected output overcurrent	Parallel system configuration, the backup current exceeds the limit value.	1. Check whether the power supply to the backup box (EDA) is normal. 2. Check whether the contactor inside the backup box (EDA) is damaged. 3. Contact the installer or manufacturer.
E035	Backup box error	Parallel system configuration, backup box (EDA) not working properly	1. Check whether the AC cable wiring matches the mains phase sequence setting. 2. Contact the installer or manufacturer.
E019	SCI error	Communication interruption between DSP and ARM	1. Restart the inverter. 2. Contact the installer or manufacturer.
E018	FLASH error	The internal memory has been disrupted by a strong external magnetic field, etc.	1. Restart the inverter. 2. Contact the installer or manufacturer.
E029	E-meter communication error	Communication error between E-Meter and WR	1. Check that the communication connection between the inverter and the meter is reliable. 2. Make sure that the meter model is compatible.
E031	AFCI communication error	Communication error between WR and AFCI module	1. Check whether the communication cable is loose, damaged, or has poor contact. 2. Contact the installer or manufacturer.
E400	BMS communication error	Communication error between BMS and WR	1. Check that the battery ID selection is correct. 2. Check whether the communication connection between the inverter and BMS is reliable. 3. Check the operating status of the battery.
E431	Battery voltage abnormal	Battery voltage deviation >100 V (value measured by the inverter and value reported by the BMS)	1. Check that the power cable is connected correctly. 2. Check the power cord for leaks or damage. 3. Check whether there is an alarm and/or protection of the battery. 4. Restart the battery after rectifying the faults and reinstalling it. If the problem persists, contact the



			manufacturer's customer service department to find a solution.
E404	Battery voltage sensor error	There may be a fault with the battery voltage sensor.	1. Restart the battery. 2. If the problem persists, contact the manufacturer's customer service department to find a solution.
E405	Battery temperature sensor error	There may be a fault with the battery temperature sensor.	1. Restart the battery. 2. If the problem persists, contact the manufacturer's customer service department to find a solution.
E406	Battery internal communication error	There may be a fault in the battery's internal communication circuit.	1. Check the connection cable between the battery module and the controller. 2. Restart the battery. If the problem persists, contact the manufacturer's customer service department to find a solution.
E407	Battery input voltage overvoltage	The battery input voltage is too high.	1. Check whether the power cables are incorrectly connected to another source. 2. Check whether the inverter is malfunctioning.
E408	Input polarity error	The polarity of the input is reversed.	1. Check whether the power cables are connected the wrong way round. 2. Check whether the inverter is malfunctioning.
E409	Battery relay error	There may be a fault in the battery relay.	1. Restart the battery. 2. If the problem persists, contact the manufacturer's customer service department to find a solution.
E410	Cell damage	Cell voltage < 2.0 V	1. Restart the battery. 2. If the problem persists, contact the manufacturer's customer service department to find a solution.
E411	Shutdown error	The system cannot be completely shut down.	1. Restart the battery. 2. If the problem persists, contact the manufacturer's customer service department for a solution.
E412	BMIC error	The sensor chip is defective.	1. Restart the battery. 2. If the problem persists, contact the manufacturer's customer service department to find a solution.
E413	Battery internal BUS error	The internal bus of the battery is faulty.	1. Restart the battery. 2. If the problem persists, contact the manufacturer's customer service department to find a solution.
E414	Self-test error	Self-test failed	1. Restart the battery. 2. If the problem persists, contact the manufacturer's customer service department to find a solution.
E415	Safety function error	Chip self-test failed	1. Restart the battery. 2. If the problem persists, contact the manufacturer's customer service department to find a solution.
E416	Insulation fault	The insulation is too low on the battery side	1. Turn off the entire system. 2. Check devices, cables, connections, etc. for damage or breaks. 3. Check for short circuits caused by foreign objects. 4. Restart the battery after rectifying the faults. If the problem persists, contact the manufacturer's customer service department to find a solution.
E417	Cell undervoltage (error)	The cell voltage is too low, triggering the protection.	1. Check whether there is a malfunction in the inverter that is preventing the forced charge from being carried out. 2. Check whether the external source (PV, mains, diesel generator, etc.) is no longer working, which is preventing the forced charge from being carried out. 3. Restart the device and charge the battery immediately.
E418	Cell overvoltage (error)	The cell voltage is too high, triggering the protection.	1. Check whether there is a malfunction in the inverter that is preventing the forced discharge from being carried out. 2. Check whether there is an inappropriate setting and/or configuration that is preventing the forced discharge from being carried out. 3. Restart the device and then immediately discharge the battery.
E419	Battery tower (cluster) undervoltage (error)	The cluster voltage is too low, triggering the protection.	1. Check whether there is a malfunction in the inverter that is preventing the forced charge from being carried out. 2. Check whether the external source (PV, mains, diesel generator, etc.) is no longer working, which would prevent forced charging from taking place. 3. Restart the device and charge the battery immediately.
E420	Battery tower (cluster) overvoltage	The cluster voltage is too high, triggering the protection.	1. Check whether there is a malfunction in the inverter that is preventing the forced discharge from being



	(error)		<p>performed.</p> <ol style="list-style-type: none"> 2. Check whether there is an inappropriate setting and/or configuration that is preventing the forced discharge from being performed. 3. Restart the device and then immediately discharge the battery.
E421	Temperature too low for charging (error)	The temperature is too low for charging, triggering the protection.	<ol style="list-style-type: none"> 1. Check whether the battery temperature is appropriate. 2. Check whether there is a malfunction of the temperature sensors. 3. Increase the ambient temperature to warm up the battery, then restart the battery.
E422	Temperature too high for charging (error)	The temperature is too high for charging, triggering the protection.	<ol style="list-style-type: none"> 1. Check whether the battery temperature is appropriate. 2. Check whether there is a malfunction of the temperature sensors. 3. Lower the ambient temperature to cool the battery, then restart the battery.
E423	Temperature too low for discharge (error)	The temperature is too low for discharge, triggering the protection.	<ol style="list-style-type: none"> 1. Check whether the battery temperature is appropriate. 2. Check whether there is a malfunction of the temperature sensors. 3. Increase the ambient temperature to warm up the battery, then restart the battery.
E424	Temperature too high for discharge (error)	The temperature is too high for discharge, triggering the protection.	<ol style="list-style-type: none"> 1. Check whether the battery temperature is appropriate. 2. Check whether there is a malfunction of the temperature sensors. 3. Lower the ambient temperature to cool the battery, then restart the battery.
E425	Charging overcurrent (error)	The charging current is too high, triggering the protection.	<ol style="list-style-type: none"> 1. Check whether the battery's current limit has been reduced due to temperature, state of charge, etc. 2. Check whether the inverter is charging in accordance with the current limitation. 3. Restart the battery after checking or adjusting the inverter configuration.
E426	Discharge overcurrent (error)	The discharge current is too high, triggering the protection.	<ol style="list-style-type: none"> 1. Check whether the current limit of the battery has been reduced due to temperature, state of charge, etc. 2. Check that the inverter is not discharging in accordance with the current limit. 3. Restart the battery after checking or adjusting the inverter configuration.
E427	Battery module undervoltage (error)	The voltage of the battery module is too low, triggering the protection.	<ol style="list-style-type: none"> 1. Check whether there is a malfunction in the inverter that is preventing the forced charging from being carried out (). 2. Check whether the external source (PV, mains, diesel generator, etc.) is no longer working, which is causing the forced charging not to be performed. 3. Restart the device and charge the battery immediately.
E428	Battery module overvoltage (error)	The voltage of the battery module is too high, triggering the protection.	<ol style="list-style-type: none"> 1. Check whether there is a malfunction in the inverter that is preventing the forced discharge from being performed. 2. Check whether there is an inappropriate setting and/or configuration that is preventing the forced discharge from being carried out. 3. Restart the device and then immediately discharge the battery.
E429	Connection Overheating (Error)	The temperature at the connection is too high, triggering the protection.	<ol style="list-style-type: none"> 1. Check whether the temperature at the connection is appropriate and whether the connection is properly established. 2. Check whether there is a malfunction of the temperature sensors. 3. Lower the ambient temperature to cool the connection, then restart the battery.
E430	Fault current (error)	The fault current is too high, which triggers the protection.	<ol style="list-style-type: none"> 1. Switch off the entire system. 2. Check devices, cables, connections, etc. for damage or breaks. 3. Check whether foreign objects have caused short circuits. 4. Restart the battery after rectifying the faults.
I400	Cell undervoltage (info)	The cell voltage is too low, triggering the alarm.	<ol style="list-style-type: none"> 1. Check whether there is a malfunction or incorrect configuration of the inverter that is causing continuous discharge. 2. Check for any obvious deviation in the cell voltage. 3. Charge the battery immediately. 4. If there is a deviation in the cell environment, fully



			charge and discharge the battery several times (>10 cycles). If the problem persists, contact the manufacturer's customer service department to find a solution.
I401	Cell overvoltage (info)	The cell voltage is too high, triggering the alarm.	<ol style="list-style-type: none"> 1. Check whether there is a malfunction or incorrect configuration of the inverter that is preventing the protection from being implemented in accordance with the charging voltage limit. 2. Check for an inappropriate setting and/or configuration that is preventing forced discharge from being performed. 3. Discharge the battery immediately. 4. If there is a deviation in the cell voltage, charge and discharge the battery completely several times (>10 cycles). If the problem persists, contact the manufacturer's customer service department to find a solution.
I402	Battery tower (cluster) undervoltage (info)	The cluster voltage is too low, triggering the alarm.	<ol style="list-style-type: none"> 1. Check whether there is a malfunction or incorrect configuration of the inverter that is causing continuous discharge. 2. Check whether the load power is oversized. 3. Charge the battery immediately.
I403	Battery tower (cluster) Overvoltage (info)	The cluster voltage is too high, triggering the alarm.	<ol style="list-style-type: none"> 1. Check whether there is a malfunction or incorrect configuration of the inverter that is preventing the protection from being implemented in accordance with the charge limitation. 2. Check whether there is an unsuitable setting and/or configuration that is preventing forced discharge from being performed. 3. Discharge the battery immediately.
I404	Temperature too low for charging (info)	The temperature is too low for charging, which triggers the alarm.	<ol style="list-style-type: none"> 1. Check whether the battery temperature is appropriate. 2. Check whether there is a malfunction in the temperature sensors. 3. Increase the ambient temperature to warm up the battery.
I405	Temperature too high for charging (info)	The temperature is too high for charging, which triggers the alarm.	<ol style="list-style-type: none"> 1. Check whether the battery temperature is appropriate. 2. Check for a malfunction of the temperature sensors. 3. Lower the ambient temperature to cool the battery or reduce the charging current.
I406	Temperature too low for discharge (info)	The temperature is too low for discharge, triggering the alarm.	<ol style="list-style-type: none"> 1. Check whether the battery temperature is appropriate. 2. Check whether there is a malfunction of the temperature sensors. 3. Increase the ambient temperature to warm up the battery.
I407	Temperature too high for discharge (info)	The temperature is too high for discharge, triggering the alarm.	<ol style="list-style-type: none"> 1. Check whether the battery temperature is appropriate. 2. Check whether there is a malfunction of the temperature sensors. 3. Lower the ambient temperature to cool the battery or reduce the discharge current.
I408	Charging overcurrent (info)	The charging current is too high, triggering the alarm.	<ol style="list-style-type: none"> 1. Check whether the battery's current limitation has been reduced due to temperature, charge status, etc. 2. Check whether the inverter is charging in accordance with the current limitation. 3. Restart the battery after checking or adjusting the inverter configuration.
I409	Discharge overcurrent (info)	The discharge current is too high, triggering the alarm.	<ol style="list-style-type: none"> 1. Check whether the current limit of the battery has been reduced due to temperature, state of charge, etc. 2. Check whether the inverter is discharging in accordance with the current limitation. 3. Restart the battery after checking or adjusting the inverter configuration.
I410	Battery module undervoltage (info)	The voltage of the battery module is too low, triggering the alarm.	<ol style="list-style-type: none"> 1. Check whether there is a malfunction or incorrect configuration of the inverter that is causing continuous discharge. 2. Check whether the load power is oversized. 3. Charge the battery immediately.
I411	Battery module overvoltage (info)	The voltage of the battery module is too high, triggering the alarm.	<ol style="list-style-type: none"> 1. Check whether there is a malfunction or incorrect configuration of the inverter that is preventing the protection function from being performed in accordance with the charge limit. 2. Check whether there is an unsuitable setting and/or configuration that is preventing the forced discharge from being carried out.



			3. Discharge the battery immediately.
I412	Connection Overheating (Ifno)	The connection is too warm, which triggers the alarm.	<ol style="list-style-type: none"> 1. Check whether the temperature of the connection is appropriate and whether the connection is properly established. 2. Check whether there is a malfunction of the temperature sensors. 3. Lower the ambient temperature to cool the connection, then restart the battery.
I413	Battery fan error (info)	The battery module fan is not working properly.	<ol style="list-style-type: none"> 1. Turn off the battery and check that the fan power cord is properly connected. 2. Contact the manufacturer's customer service department to find a solution.
I414	Fault current (Ifno)	The fault current is too high, triggering the alarm.	<ol style="list-style-type: none"> 1. Switch off the entire system. 2. Check devices, cables, connections, etc. for damage or breaks. 3. Check whether foreign objects have caused short circuits. 4. Restart the battery after rectifying the faults.
W400	Cell undervoltage (warning)	The cell voltage is too low, triggering the warning.	<ol style="list-style-type: none"> 1. Check whether there is a malfunction or incorrect configuration of the inverter that is causing continuous discharge. 2. Check for any obvious deviation in the cell voltage. 3. Charge the battery immediately. 4. If there is a deviation in the cell voltage, fully charge and discharge the battery several times (>10 cycles). If the problem persists, contact the manufacturer's customer service department to find a solution.
W401	Cell overvoltage (warning)	The cell voltage is too high, triggering the warning.	<ol style="list-style-type: none"> 1. Check whether there is a malfunction or incorrect configuration of the inverter that prevents the " " from performing the protection according to the charging voltage limit. 2. Check whether there is an unsuitable setting and/or configuration that prevents forced discharge from being performed. 3. Discharge the battery immediately. 4. If the cell voltage deviates, fully charge and discharge the battery several times (>10 cycles). If the problem persists, contact the manufacturer's customer service department to find a solution.
W402	Battery tower (cluster) undervoltage (warning)	The cluster voltage is too low, triggering the warning.	<ol style="list-style-type: none"> 1. Check whether there is a malfunction or incorrect configuration of the inverter that is causing continuous discharge. 2. Check whether the load power is oversized. 3. Charge the battery immediately.
W403	Battery tower (cluster) Overvoltage (warning)	The cluster voltage is too high, triggering the warning.	<ol style="list-style-type: none"> 1. Check whether there is a malfunction or incorrect configuration of the inverter that prevents the protection from being implemented in accordance with the charge limitation. 2. Check whether there is an unsuitable setting and/or configuration that is preventing forced discharge from being performed. 3. Discharge the battery immediately.
W404	Temperature too low for charging (warning)	The temperature is too low for charging, which triggers the warning.	<ol style="list-style-type: none"> 1. Check whether the battery temperature is appropriate. 2. Check whether there is a malfunction in the temperature sensors. 3. Increase the ambient temperature to warm up the battery.
W405	Temperature too high for charging (warning)	The temperature is too high for charging, triggering the warning.	<ol style="list-style-type: none"> 1. Check whether the battery temperature is appropriate. 2. Check whether there is a malfunction of the temperature sensors. 3. Lower the ambient temperature to cool the battery or reduce the charging current.
W406	Temperature too low for discharge (warning)	The temperature is too low for discharge, triggering the warning.	<ol style="list-style-type: none"> 1. Check whether the battery temperature is appropriate. 2. Check whether there is a malfunction of the temperature sensors. 3. Increase the ambient temperature to warm up the battery.
W407	Temperature too high for discharge (warning)	The temperature is too high for discharge, triggering the warning.	<ol style="list-style-type: none"> 1. Check whether the battery temperature is appropriate. 2. Check whether there is a malfunction in the temperature sensors. 3. Lower the ambient temperature to cool the battery or reduce the discharge current.



W408	Charging overcurrent (warning)	The charging current is too high, triggering the alarm.	<ol style="list-style-type: none"> 1. Check whether the current limit of the battery has been reduced due to temperature, state of charge, etc. 2. Check whether the inverter is charging in accordance with the current limitation. 3. Restart the battery after checking or adjusting the inverter configuration.
W409	Discharge overcurrent (warning)	The discharge current is too high, triggering the alarm.	<ol style="list-style-type: none"> 1. Check whether the current limit of the battery has been reduced due to temperature, state of charge, etc. 2. Check whether the inverter is discharging in accordance with the current limit. 3. Restart the battery after checking or adjusting the inverter configuration.
W410	Battery module undervoltage (warning)	The voltage of the battery module is too low, triggering the warning.	<ol style="list-style-type: none"> 1. Check whether there is a malfunction or incorrect configuration of the inverter that is causing continuous discharge. 2. Check whether the load power is oversized. 3. Charge the battery immediately.
W411	Battery module overvoltage (warning)	The voltage of the battery module is too high, triggering the warning.	<ol style="list-style-type: none"> 1. Check whether there is a malfunction or incorrect configuration of the inverter that is preventing the protection function from being performed in accordance with the charge voltage limitation. 2. Check whether there is an unsuitable setting and/or configuration that prevents the forced discharge from being carried out in accordance with the charge voltage limit (). 3. Discharge the battery immediately.
W412	BMS offline (warning)	BMS (BMU) in the battery module is offline	Switch off the battery and contact the manufacturer's customer service department to find a solution.
W414	Battery module SN change (warning)	Battery module(s) changed	<ol style="list-style-type: none"> 1. Check whether a battery module has been removed or added. 2. Check that the SOC and voltage of all added battery modules are identical. 3. Contact the installer, dealer, or manufacturer's customer service for confirmation and troubleshooting.
W415	Change in battery tower (cluster) voltage too high (warning)	The cluster voltage changes too much within 2 seconds.	<ol style="list-style-type: none"> 1. Check that the power cord is connected correctly. 2. Check for any unusual changes in voltage and charge status. 3. Restart the battery after correcting the errors. If the problem persists, contact the manufacturer's customer service department to find a solution.
W416	Abnormal voltage change in the battery tower (cluster) ΔV (warning)	There are visible voltage deviations between the clusters.	<ol style="list-style-type: none"> 1. Check that the power cord is properly connected. 2. Check for any unusual changes in voltage and charge status. 3. Check that the battery mode and number of batteries in each cluster are identical. 4. Restart the battery after resolving the anomalies. If the problem persists, contact the manufacturer's customer service department to find a solution.
W417	Abnormal voltage change in the battery module ΔV (warning)	There is a visible voltage deviation between the battery modules.	<ol style="list-style-type: none"> 1. Check that the power cord is properly connected. 2. Check for any unusual changes in voltage and charge status. 3. Restart the battery after rectifying the faults. If the problem persists, contact the manufacturer's customer service department to find a solution.
S01	Abnormal operating mode	The inverter cannot generate power because the operating mode has not been set.	1. Configure a suitable mode via the monitoring platform or the inverter display.
S02	Emergency	This occurred in a situation where someone activated the emergency stop switch connected to the inverter.	1. If it was not triggered manually, check that the emergency stop switch on the device settings page of the monitoring platform is set correctly.
S03	DC voltage abnormal	The inverter cannot generate power because the DC voltage exceeds the limit value.	<ol style="list-style-type: none"> 1. Check the DC voltage to ensure that it is within the inverter's permissible range. 2. Check whether the status of the battery BMS is normal.
S04	Mains fault	The inverter cannot generate power due to a mains voltage or frequency that exceeds the permissible range.	1. Check the grid voltage and frequency.
S05	Off-grid switched off	On/off-grid setting not activated.	1. Please switch the switch on the device settings page of the monitoring platform to On.
S06	Off-grid battery abnormal	The inverter cannot be used in off-grid mode without a battery.	1. Normal operation will resume once the power supply is restored.

S0	"Stop" command activated	The inverter stops power generation due to a shutdown command received.	1. Restart the inverter to resume power generation.
S08	SOC low and no PV	In off-grid operation, the inverter switches to standby mode when the state of charge (SOC) falls below the off-grid SOC protection value or the battery discharge is deactivated and no PV power is available.	1. This problem disappears when the SOC is higher than the trigger value or the PV side is supplied with power.
S09	Communication error in parallel operation	A communication error on a slave inverter causes the master inverter to enter a " " standby state.	1. Check the communication status of the slave inverter.
S10	E-meter communication error during "Hard Control"	The inverter is in a waiting state in hard control of the export limitation due to a communication error of the meter.	1. Check the communication status of the E-meter.
S11	Waiting for bypass status	The inverter is in bypass self-test mode after being switched on for the first time.	1. Normal operation will resume in approximately 15 seconds.
S11	Standby status after FW update	After a firmware upgrade, the inverter waits for the bypass to be entered.	1. Normal operation will resume in approximately 30 seconds.
S13	Diesel generator error	The inverter is in power limitation mode due to a faulty diesel generator.	1. Check the status of the diesel generator.
S18	Mains overfrequency causes power limitation	The inverter is limiting the power because the mains frequency exceeds the permissible range specified in the safety regulations.	1. The problem will be resolved automatically once the mains frequency returns to normal.
S19	Overtemperature causes power limitation	The inverter limits the power due to high temperatures in the power module or in the interior.	1. The problem will resolve automatically when the temperature drops.
S20	Overcurrent leads to power limitation	The inverter limits the power when the output current reaches the maximum limit due to a low grid voltage.	1. The problem is automatically resolved as soon as the mains voltage returns to normal.
S21	Reactive power limitation	The active power (P) is reduced due to high reactive power (Q).	1. The active power output (P) automatically returns to normal as soon as the reactive power output (Q) decreases.
S22	Feed-in limitation leads to power limitation	The inverter limits the power due to the activated export limitation.	1. Check the settings for the export limit and ignore the warning message if they are correct.
S23	Slow charging	The inverter is charging slowly due to regulatory requirements during start-up and reconnection.	1. The notification should disappear after a while.
S24	Overvoltage leads to power limitation	The inverter limits the power because the AC voltage exceeds the permissible range.	1. The problem resolves automatically as soon as the mains voltage returns to normal.
S25	Grid connection limit (at the inverter) leads to power limitation	The inverter actively reduces the output power if the power at the grid connection point exceeds the specifications.	1. The problem is automatically resolved as soon as the power supply to the on-grid port returns to normal.
S26	EMS command leads to power limitation	The inverter limits the power based on external EMS commands.	1. Ignore the warning message if an EMS device is connected.
F101	Connection or network error	The system cannot connect to the Internet.	Check the network connection, check the network adapter if necessary. Install without Devolo or similar devices such as repeaters/dLAN/Powerline. Restart LiveX by turning the fuse off and then on again.
	Network load capacity reduced (§ 14a)	The load capacity is temporarily reduced in accordance with § 14a EnWG.	Wait until the system is allowed to increase the power.
W103	Calibration charge not completed	Calibration charge could not be completed. SOC (state of charge) does not reach 100% even after a long period of time.	Inform installer, restart calibration charge. If this is not successful, check batteries.
W104	Calibration charge	Calibration charge to protect the battery, every 20 days without a full charge	Wait, the system will balance all cells until the battery is full. No intervention necessary.
F109	Mains energy meter not working	The system is not receiving any data from the energy meter. Energy	No communication with the energy meter. This is normal in the event of a power failure, so wait



		meter not working or communication problem	until the power is back on. Otherwise, notify the installer.
F110	The energy meter of the external PV system is not working	The system is not receiving any data from the energy meter. Energy meter not working or communication problem	No communication with the energy meter. This is normal in the event of a power failure, so wait until the power is back on. Otherwise, notify the installer.
F111	External energy meter memory is not working	The system is not receiving any data from the energy meter. Energy meter not working or communication problem	No communication with the energy meter. This is normal in the event of a power failure, so wait until the power is back on. Otherwise, notify the installer.
F112	User energy meter 1 is not working	The system is not receiving any data from the energy meter. Energy meter not working or communication problem	No communication with the energy meter. This is normal during a power failure, so wait until the power is back on. Otherwise, notify the installer.
F113	User energy meter 2 is not working	The system is not receiving any data from the energy meter. Energy meter not working or communication problem	No communication with the energy meter. This is normal in the event of a power failure, so wait until the power is back on. Otherwise, notify the installer.
F114	User energy meter 3 is not functioning	The system is not receiving any data from the energy meter. Energy meter not working or communication problem	No communication with the energy meter. This is normal during a power outage, so wait until the power comes back on. Otherwise, notify the installer.
F115	User energy meter 4 is not working	The system is not receiving any data from the energy meter. Energy meter not working or communication problem	No communication with the energy meter. This is normal in the event of a power failure, so wait until the power is back on. Otherwise, notify the installer.

